



Marc Elrich
County Executive

Luisa F. Cardona
Mid-County Area Regional Director

MID-COUNTY CITIZENS ADVISORY BOARD

NEW MEMBER ORIENTATION HANDBOOK

April 2024



MID-COUNTY CITIZENS ADVISORY BOARD

Marc Elrich
County Executive

Arquilla Ridgell
Board Chair

Luisa F. Cardona
Regional Director

TABLE OF CONTENTS

Section 1:Background Info & History	Page 2
• Regional Services Center Mission	3
• Brief History of Mid-County Regional Services Center.....	4
• Resolution Establishing Citizen Advisory Boards	5
• Montgomery County Organizational Chart	8
• Montgomery County Budget Process	9
Section 2:Montgomery County Boards, Committees and Commissions	Page 17
• Montgomery County Code on Boards, Committees and Commissions	18
• Boards, Committees, Commissions Policies and Procedures	23
• Board Staff and Chair Responsibilities	29
• Best Practices: Preparing Minutes	30
• Complying with Open Meetings Act	31
• Montgomery County Ethics Law	37
• Attendance Policy	55
• Important Websites to Know	58
Section 3:MCCAB Structure	Page 59
• MCCAB Operating Procedures and Membership Guidelines	60
• MCCAB Subcommittee Descriptions	64
• General Volunteer Registration Form	65
• Reimbursement form for Members	66
Section 4:Maps & Demographics	Page 68
• Montgomery County Regional Services Centers	69
• Mid-County Regional Services Area Map	70
• Wheaton Urban District Map	71
• Mid-County Community Information & Facts	73
• Mid-County Fact Sheet	86

Section 1:
Background Info & History

Regional Services Centers Descriptions

Mission

The Regional Services Centers (RSCs) are the local offices for Montgomery County Government. Beginning in 1975, the Council charged the Regional Services Centers with leading interagency efforts to:

- Strengthen communication between the community and various agencies of County Government
- Coordinate necessary interagency action with respect to each local area
- Serve as staff liaisons for committees and advisory boards
- And recommend programs and policies tailored to the local community

Each Regional Service Centers offers many ways to get involved in local government including advisory committees, volunteer opportunities, educational opportunities, public meetings, open houses and more.

Goals

The RSCs accomplish their mission by:

Improving Access to Services

- Improving access to and information about County services.
- Serving as ambassadors for information sharing and problem solving.
- Creating gathering places – virtual and physical spaces for communities.
- Assuring the delivery of responsive, accessible government services that recognize the special characteristics, needs, and resources of each distinct region.

Empowering Communities

- Becoming focal points for collaboration with stakeholders including neighborhoods, individuals, businesses, nonprofits, schools, and County agencies.
- Building stakeholder group capacity.
- Developing and maintain partnerships for local service delivery and stewardship.
- Providing problem-solving assistance.

Improving the Organization

- Building skills and knowledge within government.
- Identifying future service needs.
- Integrating community intelligence into decision-making.

A BRIEF HISTORY OF THE MID-COUNTY REGIONAL CENTER



The Mid-County Regional Services Office is one of five regional services area offices designed to bring direct services to the public and to enhance communication between residents and County government. The Office's four core functions include:

- 1) coordinating projects among multiple agencies in their respective region.
- 2) assisting department with outreach to communities (and vice versa);
- 3) providing additional knowledge to departments about their respective regions (and vice versa) and
- 4) helping departments be responsive to the community's needs.

The Office is led by the Mid-County Regional Office Director who offers problem solving, information, and referrals to residents and businesses. Staff work directly with residents, community groups, businesses, the Mid-County Citizens Advisory Board, the Wheaton Urban District Advisory Committee, and numerous public and private agencies to assess regional area problems, to determine solutions that emphasize cooperative efforts, and to foster public-private partnerships.

The Mid-County Office staff provide:

- Information about direct services
- Responses to requests for services
- Problem solving assistance and advice
- Staffing of Mid-County and Wheaton Boards and Committees
- Referrals to other agencies

Over the years, the Mid-County Office has helped to facilitate many public-private partnerships for the benefit of the residents and businesses located throughout the 99 square miles that make up the service area for the Mid-County Regional Office.

HISTORY

The Mid-County Services Center (formerly known as the Wheaton Government Service Center) opened in May 1978 as Montgomery County's second full service satellite county government office. The Center was constructed with County funds that matched a Federal grant from the then U.S. Department of Health, Education, and Welfare (HEW) to bring mental health services to localities.

Currently, the Center serves a population of approximately 220,000 individuals and businesses in an area that extends from the Beltway to Howard County and includes such communities as Ashton, Aspen Hill, Brookeville, Capital View, Derwood, Forest Glen, Glenmont, Kemp Mill, Kensington, Layhill, Norbeck, Olney, Sandy Spring, Upper Rock Creek, and Wheaton.

The first Director of the Center was Meg Riesett (1978-1985) who was succeeded by Freda J. Mauldin (1985-1994), Natalie Cantor served from (1994-2011) who was succeeded by Ana Lopez van Balen (2011-2015) who was succeeded by Luisa Montero-Diaz (2015-2021) The current director, Luisa F. Cardona, began serving August 2021

COUNTY COUNCIL
FOR MONTGOMERY COUNTY, MARYLAND

By: County Council

SUBJECT: Official Establishment of the Wheaton Center Citizens Advisory Board and Confirmation of County Executive's Appointments to this Board

WHEREAS, on September 2, 1975, by Resolution No. 8-449, the County Council recommended that the County Executive establish area Citizens Advisory Boards for centers similar to the Silver Spring Center when such centers were established in the future; and

WHEREAS, the County Council recommended that the Citizens Advisory Board be large enough that it could be divided into area subcommittees as necessary; and

WHEREAS, the Board should be constituted as to reflect the varying points of view within the community but not be an advocate for a majority position; and

WHEREAS, the Council further recommended that the geographical area to be covered should be determined after discussions with the community;

WHEREAS, the County Executive has forwarded to the Council appointments for the Wheaton Center Citizens Advisory Board;

NOW, THEREFORE, BE IT RESOLVED by the County Council for Montgomery County, Maryland that -

The Wheaton Center Citizens Advisory Board is established officially.

AND BE IT FURTHER RESOLVED that the following County Executive's appointments to the Wheaton Center Citizens Advisory Board are hereby confirmed:

Roger Arnold
Wheaton Woods Baptist Church
13200 Arctic Avenue
Wheaton

Milton Zall
606 Kenbrook Drive
Silver Spring 20902

Susan Mannina
12431 Littleton Street
Silver Spring 20906

Stanley Valadez
2330 Georgian Woods Place
Wheaton 20902

Ellen-Jane Pairo
2704 Blueridge Avenue
Wheaton 20902

Peter Marken
13410 Tangier Place
Rockville 20853

Sylvia Simpson
3918 Mertford Street
Kensington 20795

Walter Petzold
14113 Chadwick Lane
Rockville 20853

Shirley Stephens
9808 Crosby Place
Silver Spring 20910

Milton Popeck
11503 Lambertson Court
Silver Spring

A True Copy

ATTEST:



Anna P. Spates, Secretary
of the County Council for
Montgomery County, Maryland

Introduced: September 2, 1975

Adopted: September 2, 1975

COUNTY COUNCIL

FOR MONTGOMERY COUNTY, MARYLAND

By: County Council

Subject: Dissolution of the TESS Commission

WHEREAS, by Resolution No. 6-2049 dated April 29, 1969, the Montgomery County Council, in agreement with the City Council of Takoma Park, created the Takoma-East Silver Spring Commission to coordinate inter-governmental efforts towards the alleviation of social and environmental problems prevailing in the area; and

WHEREAS, by the same resolution, the County Council created a Takoma-East Silver Spring Advisory Council to advise the TESS Commission; and

WHEREAS, through the efforts of the TESS Commission and the Advisory Council, much has been accomplished by the County and City Governments working in conjunction with the community to meet the needs of the area in the form of facilities, programs, and policies; and

WHEREAS, in particular, the County Government has established the Silver Spring and TESS multi-service Community Service Centers for the continued coordination of improved governmental services; and

WHEREAS, it is the judgement of the County Council that interagency coordination should be broadened to include all parts of the County;

NOW, THEREFORE, BE IT RESOLVED that the TESS Commission and the TESS Citizens Advisory Council are hereby dissolved as of September 2, 1975 with the sincere appreciation of the County Council for a job well done over the past six-years; and

BE IT FURTHER RESOLVED that there is hereby created a new Interagency Commission, the membership of which shall consist of a representative of the County Executive who shall be the chairperson, a member of the County Council, a member of the Planning Board, and a member of the Board of Education. On those occasions when the Interagency Commission is considering matters in a part of the County which includes a municipality, the appropriate municipal officials shall be invited to participate in the sessions with the Commission. The Commission shall meet at least twice yearly, including once in the Takoma-East Silver Spring area, and at other times upon the request of any member with the approval of the County Executive and the County Council. Administration support for the Commission shall be provided as necessary by the County Executive. The Commission's function shall be to coordinate necessary interagency action on major problems or opportunities confronting the County as a whole or a particular community thereof.

BE IT FURTHER RESOLVED that the County Council hereby recommends to the County Executive that a senior level staff body be created at the Silver Spring Center, membership of which should consist of the Director of the Silver Spring Center as chairperson, and the appropriate senior staff representatives from the City of Takoma Park, the County Council, the Board of Education, and the Montgomery County Planning Board. Functions of this staff body should include strengthening communication between the community and the various agencies of the County government, coordinating necessary interagency action with regard to Silver Spring, and recommending programs and policies tailored to the Silver Spring area.

BE IT FURTHER RESOLVED that the County Council hereby recommends that the County Executive establish a Silver Spring area Citizens Advisory Board

the Silver Spring Center (and for each such center established in the future) membership to be appointed by the County Executive and confirmed by the County Council. The Council recommends that the Citizens Advisory Board be large enough that it can be divided into area subcommittees as necessary and that it be so constituted as to reflect the varying points of view within the community but not be an advocate for a majority position. The Council further recommends that the geographical area to be covered by the Silver Spring Citizens Advisory Board should generally be that area bounded by the District of Columbia Line on the South, the Rock Creek Park on the West, the Beltway on the North, and the Prince George County Line on the East. Final determination of the boundaries should be made after discussions with the community.

BE IT FURTHER RESOLVED that the County Government reaffirms its support of the Montgomery-Georgetown Health Clinic at the Piney Branch Middle School and the TESS Center at the Flower Avenue Shopping Center.

BE IT FURTHER RESOLVED that the County Council, on behalf of the County, extends its sincere and deep appreciation to the TESS Commission, TCAC and the various supporting staffs for the outstanding contribution to public interests in the community.

A True Copy.

ATTEST:

Anna P. Spates

Anna P. Spates, Secretary
of the County Council for
Montgomery County, Maryland

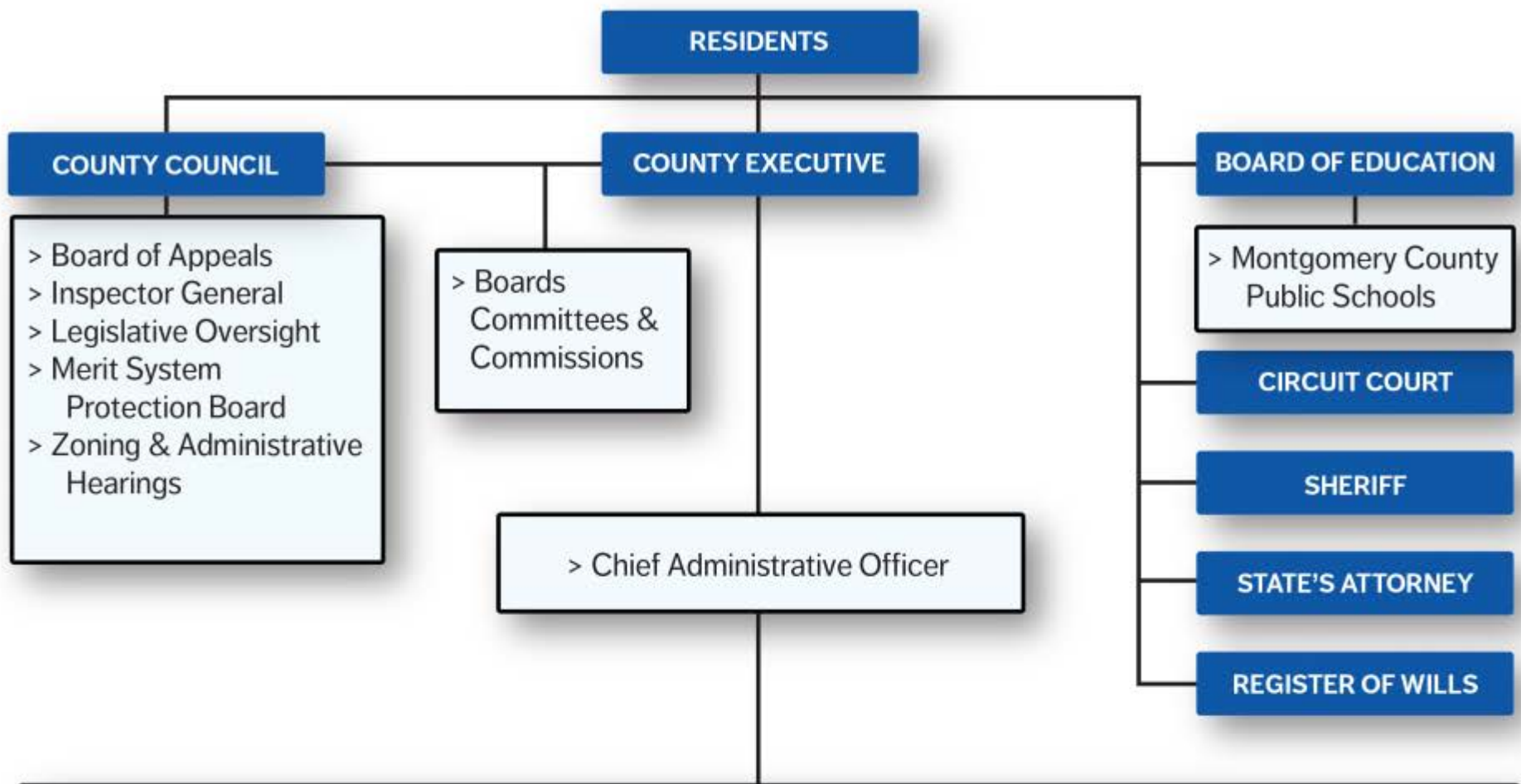

- Operational Departments**
- > Community Engagement Cluster
 - > Community Use of Public Facilities
 - > Consumer Protection
 - > Correction & Rehabilitation
 - > County Executive, Office of
 - > Environmental Protection
 - > Fire & Rescue Service
 - > Health & Human Services
 - > Housing & Community Affairs
 - > Human Rights
 - > Libraries
 - > Liquor Control
 - > Permitting Services
 - > Procurement
 - > Police
 - > Recreation
 - > Regional Services Centers
 - > Transportation
 - > Women, Commission for
- Administrative Departments**
- > County Attorney
 - > Ethics
 - > Finance
 - > General Services
 - > Human Resources
 - > Intergovernmental Relations
 - > Management & Budget
 - > Public Information
 - > Technology Services

- Other Agencies**
- > Board of Elections
 - > District Court
 - > District of Columbia Water & Sewer Authority
 - > Housing Opportunities Commission
 - > Montgomery College
 - > Maryland-National Capital Park & Planning Commission
 - > Revenue Authority
 - > Washington Metropolitan Area Transit Authority
 - > Washington Suburban Sanitary Commission



Operating Budget Process

INTRODUCTION

The Montgomery County Charter, approved by the voters in 1968 and implemented in 1970, provides for a County Council/Executive form of government. Under this form of government, the Executive develops and recommends budget proposals; the Council then authorizes expenditures and sets property tax rates. The Charter also provides for an annual six-year Public Services Program (PSP), Operating Budget, and Capital Budget and a biennial six-year Capital Improvements Program (CIP). These budgets and related fiscal and programmatic plans provide the basis for understanding, coordinating, and controlling County government programs and expenditures.

This section provides a brief introduction and refers to the legal requirements for the annual budget process, and includes descriptions of government structure and government accounting methods and funds.

THE BUDGET PROCESS

Fiscal Year

The 12-month period used to account for revenues and expenditures in Montgomery County commences on July 1 of each year and ends on June 30 of the following year. A Budget Process Flow Chart timeline appears later in this section, which displays the relationships between the Capital Budget/Capital Improvements Program (CIP), Operating Budget/Public Services Program (PSP), and Growth Policy processes across the year.

Operating and Capital Budgets

The complete County Executive's Recommended Budget includes the CIP, published by January 15 in even-numbered calendar years; the Capital Budget, published annually by January 15; and this document, the Operating Budget and PSP, published annually by March 15.

Further information about the PSP can be found later in this section. For further information about the CIP/Capital Budget, please refer to the Capital Improvements Program (CIP) section of this document.

Spending Affordability Process

The Spending Affordability process for the Operating Budget is required by Section 305 of the County Charter and Chapter 20 of the Montgomery County Code.

The County Council must set Spending Affordability Guidelines (SAG) for the Operating Budget by the second Tuesday in February after a public hearing. The guidelines must specify a ceiling on funding from property tax revenues and a ceiling on the aggregate operating budget. In adopting SAG, the Council considers the condition of the economy, the level of economic activity in the County, personal income levels, and the impact of economic and population growth on projected revenues among other relevant factors.

Along with the guidelines, the Council also adopts recommended spending allocations for the tax-supported budgets of County Government, the Board of Education, Montgomery College, the Maryland-National Capital Park and Planning Commission, debt service, and current revenue funding for the CIP.

By March 31, each agency and the Executive must also specify how, if necessary, they would reduce the budget request to reach the Council allocation.

The Charter requires the Council to approve the Operating and Capital Budgets by June 1. An aggregate operating budget that exceeds the aggregate operating budget for the preceding fiscal year by a percentage increase greater than the annual average increase of the Consumer Price Index for all urban consumers (CPI-U) in the Washington-Baltimore Metropolitan area (or any successor index) for the 12 months preceding December first of each year requires the affirmative vote of six Councilmembers. An aggregate operating budget which exceeds the SAG ceiling on the aggregate operating budget then in effect requires the affirmative vote of seven Councilmembers. The Council approved spending affordability guidelines and allocations are displayed in the Spending Affordability Comparison chart at the end of this chapter.

Limits on Revenues

Section 305 of the County Charter includes a limit on the annual increase in property tax revenues. An amendment approved in 2008 requires that real property tax revenues, with the exception of new construction and property whose zoning or use has changed, may not increase by more than the prior year revenues plus the percentage increase in the Washington-Baltimore Metropolitan area CPI-U unless there is an unanimous vote of nine Councilmembers to exceed that limit.

Operating Budget Preparation and Executive Review

Requirements for submission of, and action on, County budgets are contained in Article 3 of the County Charter. Departments and agencies prepare budget requests within guidelines established by the Executive (for the departments) and by law (for other agencies of government). These are submitted on scheduled dates for analysis by the Office of Management and Budget (OMB) and are reviewed by the Executive during the period January-March. The Executive recommends a budget which balances all agency expenditures with projected revenues to the Council by March 15.

Public Hearings

Citizen participation is essential to a fair and effective budget process. Many citizens and advisory groups work with specific departments to ensure that their concerns are addressed in departmental requests. The County Charter requires the Council to hold a public hearing not earlier than 21 days after receipt of the recommended operating budget from the Executive.

Public hearings are advertised in County newspapers. Speakers must register with the Council Office to testify at the public hearings. Persons wishing to testify should call the Council Office to register 240.777.7803. If it is not possible to testify in person at the hearings, written testimony is acceptable and encouraged. For further information and dates of the Council's public hearings on the County Executive's Recommended Operating Budget, contact the Legislative Information Office at 240.777.7910. Hearings are held in the Council Hearing Room of the Stella B. Werner Council Office Building, unless otherwise specified.

Council Budget Review

After receiving input from the public, the Council begins its review of the Executive's Recommended Operating Budget. Each agency budget is reviewed by a designated Council committee. Agency and Office of Management and Budget (OMB) representatives meet with these committees to provide information and clarification concerning the recommended budget and agency programs. In April and May, the full Council meets in regular sessions, reviews the recommendations of its committees, and takes final action on each agency budget.

Operating and Capital Budget Approval

The Charter requires that the Council approve and make appropriations annually for the operating and capital budgets by June 1. In even-numbered calendar years, the Council also approves a six-year Capital Improvements Program. Prior to June 30, the Council must set the property tax levies necessary to finance the budgets. Other sections of the Charter provide for Executive veto or reduction of items in the budget approved by the Council. The Charter prohibits expenditure of County funds in excess of available unencumbered appropriations.

Amending the Approved Operating and Capital Budgets

The Operating and Capital Budgets may be amended at any time after adoption by the Council.

Supplemental appropriations are recommended by the County Executive, specify the source of funds to finance the additional expenditures, and may occur any time after July 1 of the fiscal year. A supplemental appropriation that would comply with, avail the County of, or put into effect a grant or a Federal, State, or County law or regulation, or one that is approved after January 1 of any fiscal year, requires an affirmative vote of five Councilmembers. A supplemental appropriation for any other purpose that is approved before January 1 of any fiscal year requires an affirmative vote of six Councilmembers. The Executive may disapprove or reduce a supplemental appropriation, and the Council may re-approve the appropriation, as if it were an item in the annual budget.

Special appropriations are recommended by either the County Executive or County Council, specify the source of funds to finance the additional expenditures, and are used when it is necessary to meet an unforeseen disaster or other emergency or to act without delay in the public interest. The Council may approve a special appropriation after public notice by news release, and each special appropriation must be approved by six members of Council.

Transfers of appropriation which do not exceed ten percent of the original appropriation, may be accomplished by either: the County Executive, for transfers within or between divisions of the same department; or by the County Council, for transfers between departments, boards or commissions, or to new accounts.

Public Services Program (PSP)

Projections of County revenues relative to anticipated expenditure requirements constrain the level of public services affordable. The Public Services Program (PSP) looks to balance the growth in revenues, based on the County Executive's current revenue and fiscal policies, with the pressures affecting the future cost of services. The Charter (Section 302) requires the County Executive to submit an annual comprehensive six-year program for public services and fiscal policy. The PSP includes:

- a statement of program objectives;
- recommended levels of public service;
- an estimate of costs over the six-year period;
- a statement of revenue sources;
- estimated impact of the PSP on County revenues and the capital budget; and
- projected revenues and expenditures for all functions of the County government.

The Charter requires that the annual budget, submitted in conjunction with the PSP, be consistent with the six-year program.

Recommended levels of public service can be seen in the six-year projections of expenditures for each special fund. Expenditures are projected based on major known commitments. Actual costs, over time, are the result of several variables, including collective bargaining, government policy, and objectives of fairness between agencies and employee groups.

An estimate of the impact of the Public Services Program on County revenues is included, where applicable, in the program descriptions or in the fiscal data for the department or agency. Impact on the program of the Capital Budget is included,

Montgomery County, Maryland Functional Organization Chart

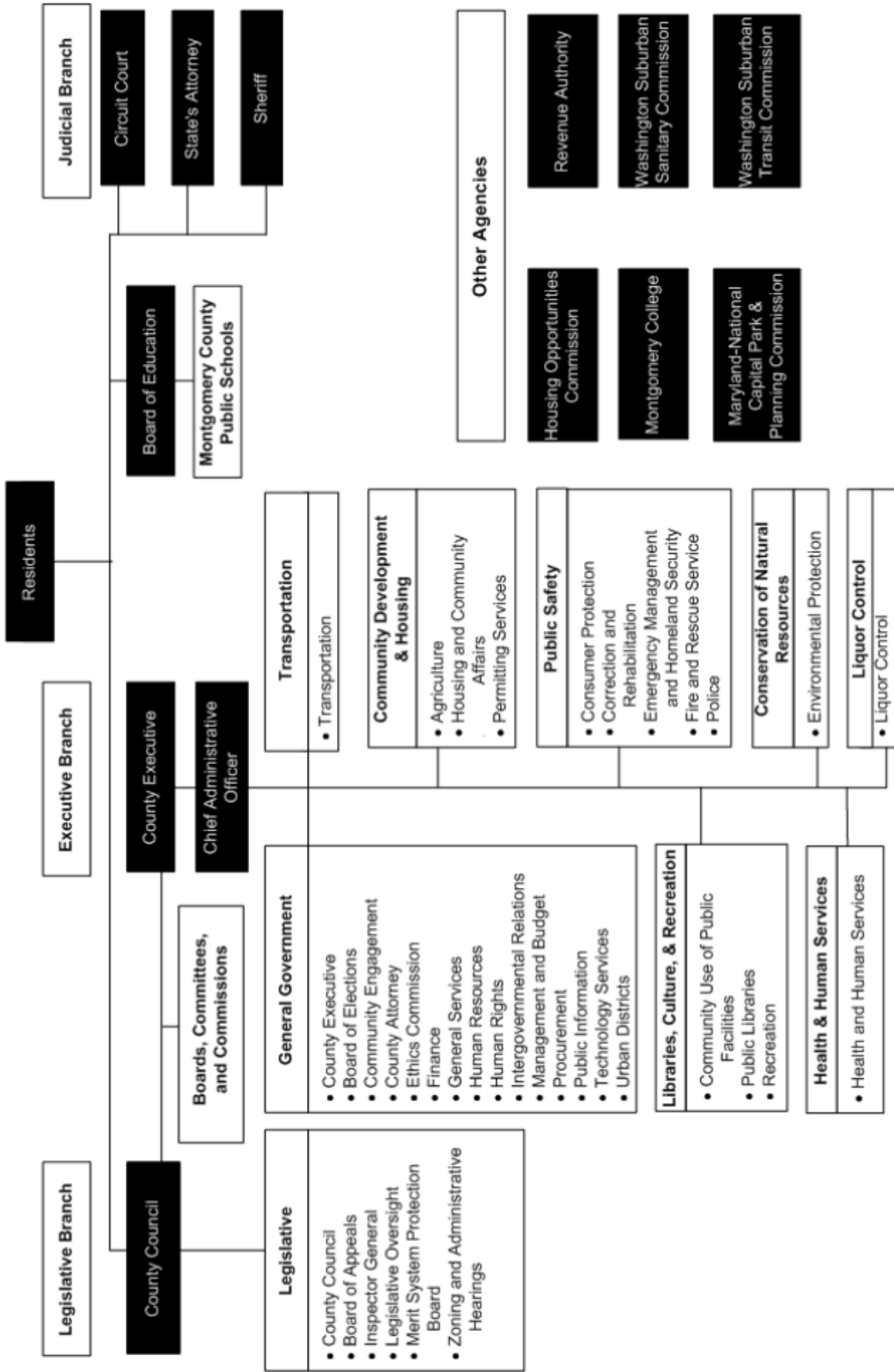

MONTGOMERY COUNTY PUBLIC DOCUMENTS:
ANNUAL BUDGETS, GROWTH POLICY, AND OTHER SOURCES OF INFORMATION

DATE	ITEM	AVAILABILITY
January 15th (even calendar years)	COUNTY EXECUTIVE'S RECOMMENDED CAPITAL BUDGET AND CAPITAL IMPROVEMENTS PROGRAM (CIP) <i>County Executive's Transmittal; Introductory Sections; County Government Departments; HOC; Revenue Authority; MCPS; Montgomery College; M-NCPPC; WSSC</i>	www.montgomerycountymd.gov/omb Reference copies at public libraries Office of Management and Budget (240.777.2800) (for purchase on limited basis)
January 15th (odd calendar years)	COUNTY EXECUTIVE'S RECOMMENDED CAPITAL BUDGET AND AMENDMENTS TO (PRIOR YEAR) CAPITAL IMPROVEMENTS PROGRAM <i>County Executive's Transmittal; Capital Budget; Amendments</i>	www.montgomerycountymd.gov/omb
March 15th	COUNTY EXECUTIVE'S RECOMMENDED OPERATING BUDGET AND PUBLIC SERVICES PROGRAM <i>County Executive's Transmittal; Financial Summaries; Legislative, Judicial, Executive Branch Departments; MCPS; Montgomery College; M-NCPPC; WSSC</i>	www.montgomerycountymd.gov/omb Reference copies at public libraries Office of Management and Budget (240.777.2800) (for purchase on limited basis)
March 31st	FISCAL PLAN <i>Contains estimates of costs and revenues over the six-year planning period for all Montgomery County special and enterprise funds and many Agency funds.</i>	www.montgomerycountymd.gov/omb Office of Management and Budget (240.777.2800)
June 15th (odd calendar years)	PLANNING BOARD RECOMMENDED GROWTH POLICY - STAFF DRAFT	Reference copies from M-NCPPC (301.495.4610)
mid-July (even calendar years)	APPROVED OPERATING AND CAPITAL BUDGETS, AND APPROVED CAPITAL IMPROVEMENTS PROGRAM <i>PSP and CIP Appropriation and Approval Resolutions; Operating Budget, CIP and Capital Budget Summaries; Project Description Forms for County Government Programs, HOC, Revenue Authority, MCPS, Montgomery College, M-NCPPC, and WSSC</i>	www.montgomerycountymd.gov/omb Reference copies at public libraries Office of Management and Budget (240.777.2800) (for purchase on limited basis)
mid-July (odd calendar years)	APPROVED OPERATING AND CAPITAL BUDGETS, AND APPROVED AMENDMENTS TO THE CAPITAL IMPROVEMENTS PROGRAM <i>PSP and CIP Appropriation and Approval Resolutions; Operating and Capital Budget Summaries; and selected Project Description Forms for County Government Programs, HOC, Revenue Authority, MCPS, Montgomery College, M-NCPPC, and WSSC</i>	Reference copies at public libraries Office of Management and Budget www.montgomerycountymd.gov/omb (240.777.2800) (for purchase on limited basis)
August 1 (odd calendar years)	PLANNING BOARD RECOMMENDED GROWTH POLICY - FINAL DRAFT	Reference copies from M-NCPPC (301.495.4610)

MONTGOMERY COUNTY PUBLIC DOCUMENTS:
ANNUAL BUDGETS, GROWTH POLICY, AND OTHER SOURCES OF INFORMATION

DATE	ITEM	AVAILABILITY
Late December	COMPREHENSIVE ANNUAL FINANCIAL REPORT	Reference copies at public libraries: Department of Finance (240.777.8822)

DATE	ITEM	AVAILABILITY
		www.montgomerycountymd.gov/finance (on limited basis)
Quarterly	ECONOMIC INDICATORS	Department of Finance (240.777.8866) www.montgomerycountymd.gov/finance
Monthly (To update the Economic Indicators Report)	ECONOMIC UPDATE	Department of Finance (240.777.8866) www.montgomerycountymd.gov/finance
Annually	ANNUAL INFORMATION STATEMENT	Department of Finance (240.777.8822) www.montgomerycountymd.gov/finance (on limited basis)
Available throughout the year	MONTGOMERY COUNTY HISTORICAL SOCIETY INFORMATION	Montgomery County Historical Society (301.340.2825) www.montgomeryhistory.org
Available throughout the year	MONTGOMERY COUNTY DEMOGRAPHIC INFORMATION	Maryland-National Capital Park and Planning Commission: Montgomery County Planning Board(301.495.4600) www.montgomeryplanning.org/research

BUDGET PROCESS FLOW CHART

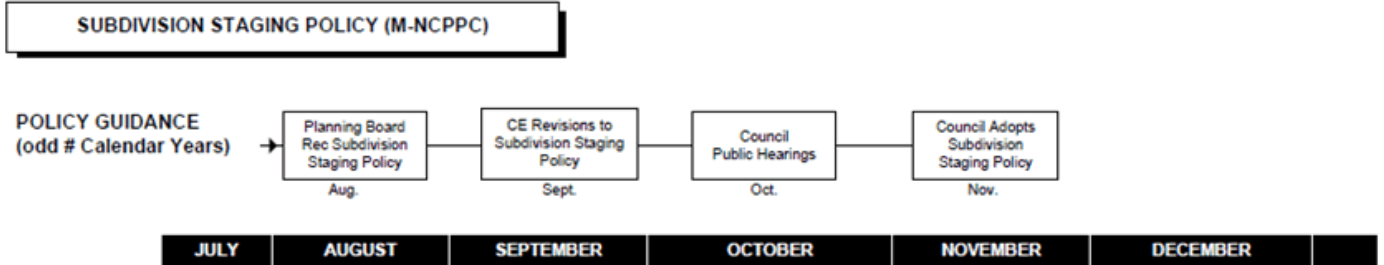
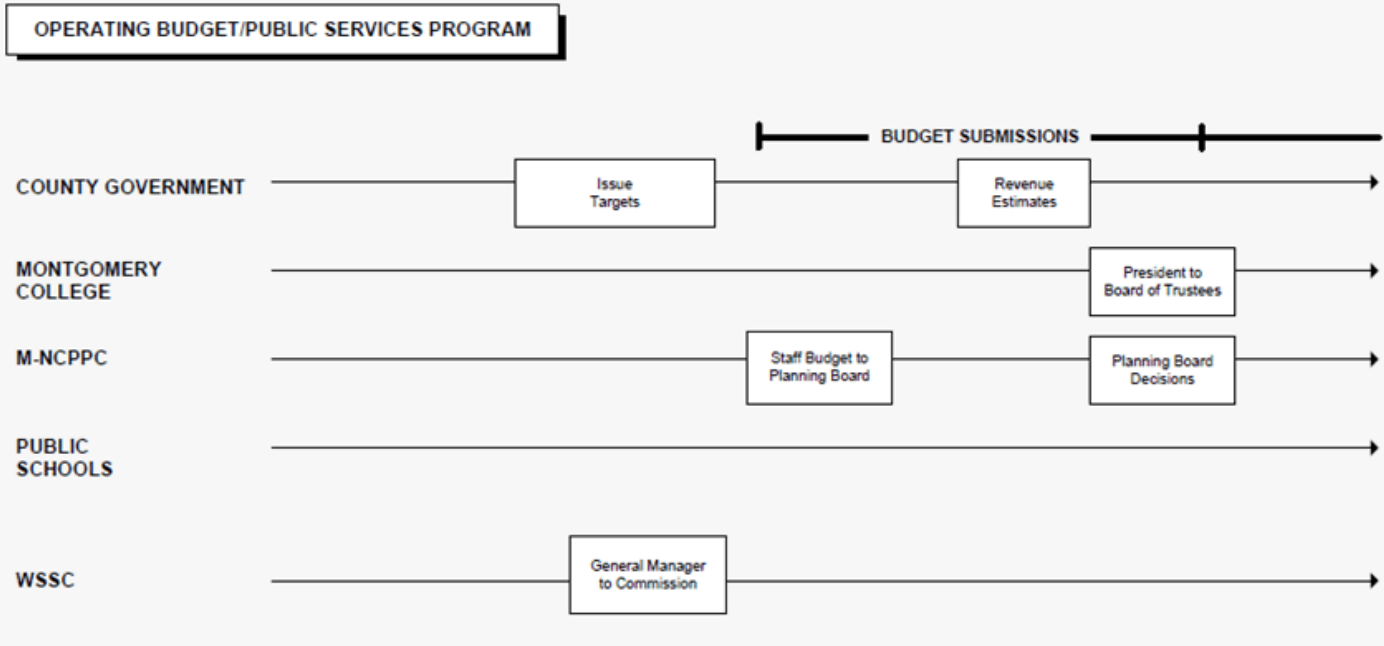
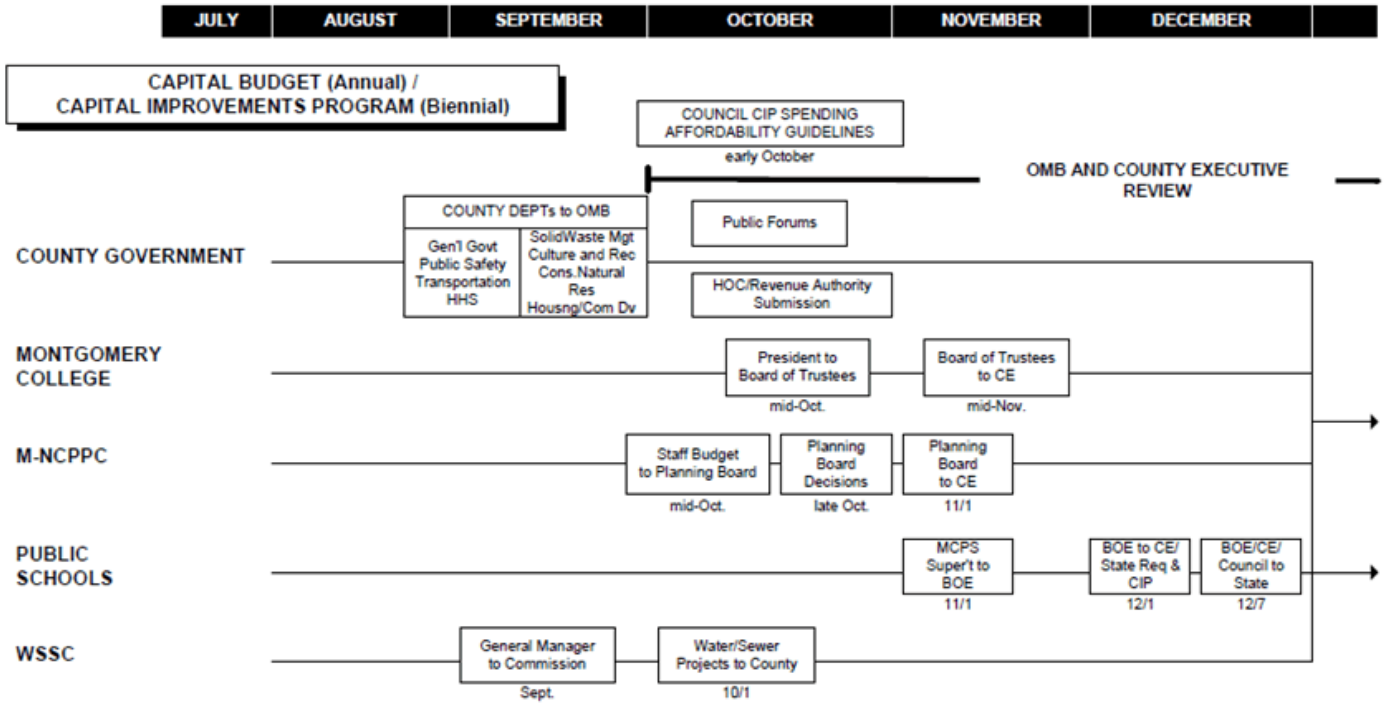

Council Revisits
CIP/SAG

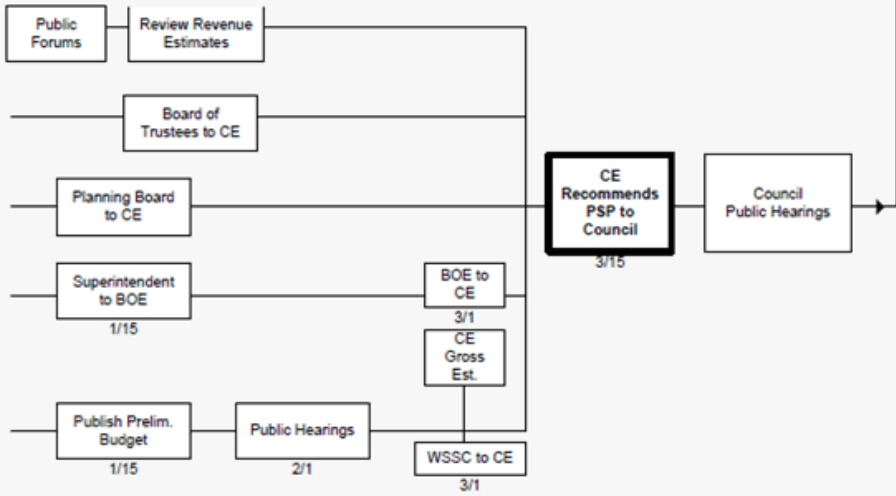
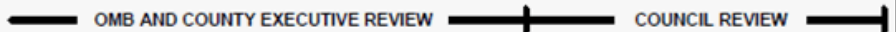
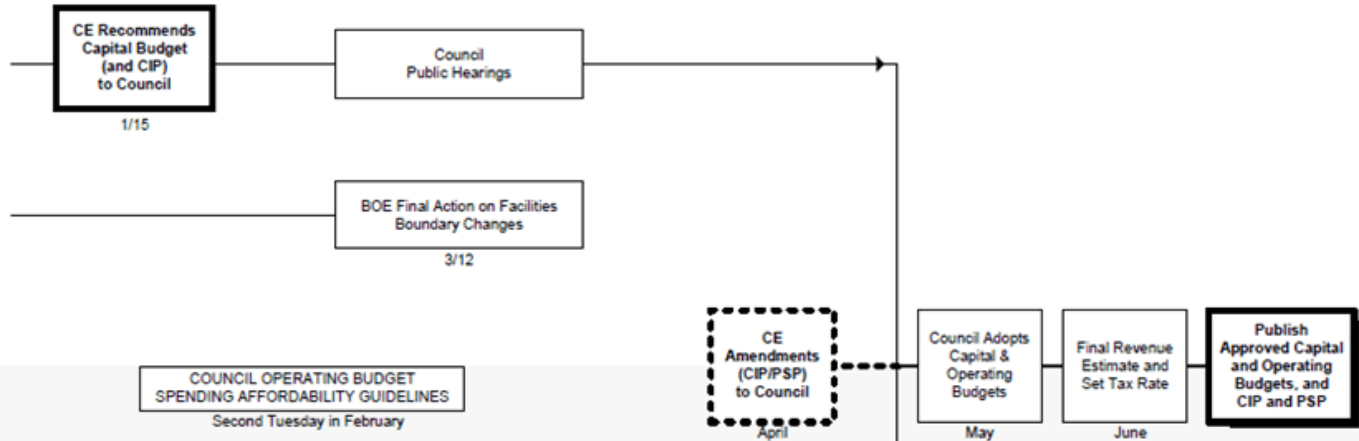
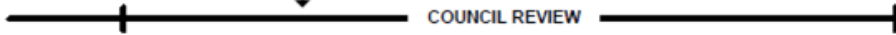

Section 2:
Montgomery County
Boards, Committees & Commissions

ARTICLE XI. BOARDS, COMMITTEES AND COMMISSIONS.* 1

***Editor's note**—[2016 L.M.C., ch. 11](#), § 2, states: “Transition. Any group created by law, resolution, or executive order after this Act takes effect must be classified as either a board, committee, commission, or task force. This Act must not be construed to require the renaming of any group that existed before this Act takes effect.”

Charter references—Merit System Protection Board, § 403 et seq.; Charter Review Commission, § 509.

Cross references—Library Board, § 2-46 et seq.; local Library Board advisory committees, § 2-51; Criminal Justice Coordinating Commission, § 2-60; Board of Health, § 2-65; County Board of Appeals, § 2-108 et seq.; Agricultural Preservation Advisory Board, § 2B-2; Animal Matters Hearing Board, § 5-104; Arts and Humanities Council, § 5A-3 et seq.; Contract Review Committee, § 11B-7; Juvenile Court Committee, § 12-36 et seq.; Board of Electrical Examiners, § 17-12 et seq.; Energy Conservation Advisory Committee, § 18A-5 et seq.; Ethics Commission, § 19A-5, et seq.; Fire and Rescue Commission, § 21-2, et seq.; Fire Board, § 21-4; Fire Corporation Boards, § 21-28 et seq.; Commission on Health, § 24-23 et seq.; Mental Health Advisory Committee, § 24-34 et seq.; Alcoholism and Other Drug Abuse Advisory Council, § 24-41 et seq.; Advisory Board on Victims and Their Families, § 24-54 et seq.; Historic Preservation Commission, ch. 24A-4; Commission on Human Rights, § 27-1 et seq.; Commission for Women, § 27-27 et seq.; Commission on Aging, § 27-34 et seq.; Community Action Agency, § 27-41; Commission on Children and Youth, § 27-47 et seq.; Citizens Review Panel, § 27-49A, et seq.; Commission on People with Disabilities, § 27-50 et seq.; Committee for Ethnic Affairs, § 27-53 et seq.; Commission on Landlord-Tenant Affairs, § 29-9 et seq.; Noise Control Advisory Board, § 31B-4; Recreation Area Advisory Boards, § 41-25 et seq.; Revenue Authority, ch. 42; Interagency Coordinating Board for Community Use of Public Facilities, § 44-3; Solid Waste Advisory Committee, § 48-38 et seq.; Range Approval Committee, § 57-2; Taxicab Services Advisory Committee, § 53-103.

Notes

¹ ***Editor's note**—[2016 L.M.C., ch. 11](#), § 2, states: “Transition. Any group created by law, resolution, or executive order after this Act takes effect must be classified as either a board, committee, commission, or task force. This Act must not be construed to require the renaming of any group that existed before this Act takes effect.”
Charter references—Merit System Protection Board, § 403 et seq.; Charter Review Commission, § 509.

Sec. 2-141. Scope of article.

It is the intent of the council to establish a uniform system for classifying all groups of the county government and for prescribing procedures for their operation. This article must therefore apply to all existing and newly created groups which function as a part of the county government, including all groups established by law, resolution, and executive order. Wherever a conflict exists between this article and state law, the state law must control. It is the intent of the council that any substantive law which creates a group covered by this act shall not be diminished or the group's responsibilities reduced in any manner whatsoever. Wherever a conflict exists between this article and existing county law, the prior county law shall control. (1979 L.M.C., ch. 22, § 1; [2016 L.M.C., ch. 11](#), § 1.)

Sec. 2-142. Definitions.

The following terms wherever used or referred to in this article shall have the following meanings:

Board means a semi-autonomous body established by federal, state or county law. A board is a formal committee with structure, duties and powers established by law. A board usually performs a quasi-judicial function, licensing, or regulation.

Commission means a body established by local law to study and recommend action to the Executive or the Council. A commission is a formal, standing committee with structure, duties and powers established by law. A commission often has an administrative or functional responsibility, such as reviewing land use plans or studying the supply of low and moderate priced housing.

Committee means a body appointed with a specific task or function. A committee makes recommendations and forwards them for appropriate action. A committee is advisory in nature and can be either a formal (standing) committee established by law or resolution, or an informal (ad hoc) committee. A committee may oversee and advise in service areas, such as housing and transportation, or it may advise the Executive or Council on specific issues and recommend policy direction.

Compensation means payment for services rendered as a committee member; it shall not include reimbursement for actual expenses incurred as a committee member.

Group means any board, committee, commission, task force, or any similar body established by federal, state, or county law, resolution or executive order, which functions as a part of the County government.

Task Force means a body appointed to study or work on a particular subject or problem. A task force ceases to exist upon completion of its charge. (1979 L.M.C., ch. 22, § 1; [2016 L.M.C., ch. 11](#), § 1.)

Sec. 2-143. Reserved.

Editor's note—Section 2-143, establishing a committee system, derived from 1979 L.M.C., ch. 22, § 1, was repealed by FY 1991 L.M.C., ch. 9, § 1.

Sec. 2-144. Budget.

Each group's staff and yearly allocation of funds, if any, must be indicated in the budget and no group must spend more than its budgeted amount. The appointing authorities must furnish such staff support as deemed necessary for each group which does not have its own staff provided for in the budget. (1979 L.M.C., ch. 22, § 1; [2016 L.M.C., ch. 11, § 1.](#))

Sec. 2-145. Compensation; reimbursement.

(a) Unless a law expressly precludes compensation, the Council may establish compensation for members of a particular group by an appropriation that funds a line item in the budget. An appropriation may establish levels of compensation by categories or subcategories or groups.

(b) Unless another method of compensation is established, a group member is compensated for each day that the member works on group business after the member is authorized to do the work by the group or the presiding officer of the group.

(c) Whether or not a group member is compensated for serving on the group, the member may request reimbursement for travel and dependent care. The rate of reimbursement is established in an appropriation.

(d) A group member must not be compensated or reimbursed for travel or childcare expenses if appropriated funds are not available. (1979 L.M.C., ch. 22, § 1; FY 1991 L.M.C., ch. 9, § 1; 1997 L.M.C., ch. 18, § 1; [2005 L.M.C., ch. 23, § 1](#); [2016 L.M.C., ch. 11, § 1.](#))

Sec. 2-146. Terms of boards, committees, commissions, and task forces.

(a) The law, resolution, or executive order establishing or continuing any board, committee, commission, or task force should specify the term of the group's existence. If no term is specified, then the board, committee, commission, or task force continues until terminated. The County Executive should monitor the expiration date of those boards, committees, commissions, and task forces that the County Executive appoints. The County Council should monitor the expiration date of those boards, committees, commissions, and task forces that the County Council appoints.

(b) Any new board, committee, commission, or task force should have from 5 to 15 voting members.

(c) *Evaluation and Review Board Committee.*

(1) The County Executive must appoint and convene at least every 6 years, subject to confirmation by the Council, a citizens review committee comprised of at least 11 members.

(2) The Committee must review the group system and each then-existing board, committee, commission, and task force and report to the Executive and Council its recommendations for changes in individual boards, committees, commissions, and task forces and the group system as a whole. The Committee must submit an interim report to the Executive and Council within 6 months of appointment and submit a final report within 12 months of appointment.

(3) The County Executive must designate the review committee's chair and vice-chair. (1979 L.M.C., ch. 22, § 1; 1984 L.M.C., ch. 37, § 1; FY 1991 L.M.C., ch. 9, § 1; 1997 L.M.C., ch. 4, § 1; [2005 L.M.C., ch. 23, § 1](#); [2011 L.M.C., ch. 21, § 1](#); [2016 L.M.C., ch. 11, § 1.](#))

Editor's note—2011 L.M.C., ch. 21, §§ 2 and 3, state:

Sec. 2. Contents of Committee Evaluation and Review Board Report. As part of its report, the first Committee Evaluation and Review Board appointed after November 8, 2011 must:

- (a) develop scenarios for reduction of County staff time used to support the committees; and
- (b) include a discussion of advisory board member workload.

Sec. 3. Continuation of certain board, committees, and commissions:

(a) *Purpose.* The County has many boards, committees, and commissions that provide a valuable service to the County with the work they perform. These boards, committees, and commissions require significant personnel and operating costs to function. In Fiscal Year 2011, the County spent an approximate \$1.4 million on personnel and operating costs to support the County's boards, committees, and commissions. While these boards, committees, and commissions provide a valuable service, there may be opportunities for consolidation.

(b) *Continuation.*

(1) In this section, the following words have the meanings indicated:

Advisory board means the following boards, committees, and commissions: Advisory Committees on Consumer Protection, Agricultural Advisory Committee, Airpark Liaison Committee, Cable and Communications Advisory Committee, Commission for Women, Commission on Aging, Commission on Child Care, Commission on Children and Youth, Commission on Health, Commission on Juvenile Justice, Commission on People with Disabilities, Commission on Veterans Affairs, Committee for Ethnic Affairs, Committee on Hate/Violence, County- wide Recreation Advisory Board, Criminal Justice Coordinating Commission, Department of Permitting Services Advisory Committee, Dickerson Area Facilities Implementation Group, Domestic Violence Coordinating Council, Down County Recreation Advisory Board, East County Citizens Advisory Board, East County Recreation Advisory Board, Energy and Air Quality Advisory Committee, Fire and Emergency Services Commission, Forest Conservation Advisory Committee, Friendship Heights TMD Advisory Committee, Library Board, Mental Health Advisory Committee, Mid-County Citizens Advisory Board, Mid-County Recreation Advisory Board, Montgomery Cares Program Advisory Board, Noise Control Advisory Board, Pedestrian and Traffic Safety Advisory Committee, Rustic Roads Advisory Committee, Silver Spring Citizens Advisory Board, Silver Spring Transportation

Management District Advisory Committee, Silver Spring Urban District Advisory Committee, Solid Waste Advisory Committee, Sustainability Working Group, Taxicab Services Advisory Committee, Technology Investment Fund Loan/Grant Committee, Upcounty Citizens Advisory Board, Upcounty Recreation Advisory Board, Victim Services Advisory Board, Water Quality Advisory Group, Western Montgomery County Citizens Advisory Board, Wheaton Urban District Advisory Committee.

Committee Evaluation and Review Board means the Board appointed under § 2-146.

(2) Each advisory board must indicate to the Committee Evaluation and Review Board, within 60 days after the Committee Evaluation and Review Board is appointed, if the advisory board should continue. Each advisory board that so indicates must provide the Committee Evaluation and Review Board with the following:

- (A) a description of the work the advisory board does;
- (B) justification for why the advisory board should be continued;
- (C) a list of accomplishments from the prior 2 years, including any direct service provided by volunteers to residents;
- (D) a discussion of advisory board member workload;
- (E) a 2-year work program; and
- (F) an explanation of the amount of government resources, including County employee staff time, used and a plan to reduce the use of those resources.

(3) In addition to the duties in § 2-146, as part of its report, the first Committee Evaluation and Review Board appointed after November 8, 2011 must review each advisory board that requests continuation under subsection (b)(2) and recommend to the Council whether the advisory board should continue.

1984 L.M.C., ch. 37, § 2 provides as follows: "If prior to the enactment of this act a committee, board, or commission expired under the terms of section 2-146 of the Montgomery County Code, then the county council hereby retroactively reestablishes such committees, boards, or commissions and reconfirms all appointments made to such bodies from the date of such expirations. All actions taken by such committees, boards or commissions during such periods of expiration shall have the same force and effect as if such expirations had not occurred."

Sec. 2-147. Group reports; by-laws.

(a) The law or resolution establishing a board, committee, commission, or task force may specify the dates when reports are due from the group and the subjects to be included in the reports. If the law or resolution is silent on the dates when reports are due, the board, committee, commission, or task force must submit an annual report on November 30 of each year to the Executive and Council containing a description of the group's functions, activities, accomplishments, plans and objectives, including recommendations for changes in group functions.

(b) The Chief Administrative Officer may prescribe a format to be followed by groups in their annual report.

(c) The Chief Administrative Officer may adopt binding guidelines, consistent with law, for the organizational structure and internal procedures of groups in the Executive branch of County government.

(d) When any group in the Executive branch adopts by-laws or any other form of internal procedures, the Chief Administrative Officer must send a copy to the Council. (1979 L.M.C., ch. 22, § 1; FY 1991 L.M.C., ch. 9, § 1; [2005 L.M.C., ch. 23](#), § 1; [2016 L.M.C., ch. 11](#), § 1.)

Sec. 2-148. Appointments, removals, and training.

(a) *Appointments.*

(1) In making appointments to groups, the appointing authority should consider the following criteria: interest, diversity of background and professions, relevant experience and expertise, and geographic balance. To promote broad participation, no individual should ordinarily serve more than 2 consecutive full terms or serve on more than one group at any one time. However, an individual may serve on more than one group at the same time if the law that created a committee requires or allows a member of that group to be selected from members of another County group.

(2) Any individual who has served 2 full terms on a group is not eligible to serve on the same group until one year has elapsed. The appointing authority may waive this restriction if:

- (A) no other qualified applicant is available; or
- (B) other unique circumstances justify the reappointment of the particular individual.

(3) Unless another term is established by the law, resolution, or executive order creating the group, the standard term for each appointment is 3 years, after any initial staggered term.

(4) A member must not continue to serve on a group after the member's term has expired, and a successor has not been appointed and confirmed, for more than 6 months unless:

- (A) another law expressly authorizes the member to serve longer; or
- (B) the Executive has notified the Council why the member will continue to serve on the group.

(b) *Removal for absenteeism.*

(1) A member of a group who misses more scheduled meetings or hearings than the number of allowed absences, computed by the following table, or who misses 3 consecutive scheduled meetings, is automatically removed. Scheduled meeting or hearing means any meeting or hearing for which at least 7 days advance notice was given and which was held as scheduled

<i>Number of Meetings Held in One Year</i>	<i>Allowed Absences</i>
1-4	1
5-8	2
9-12	3
13-16	4
17+	5

(2) An automatic removal under this subsection takes effect 30 days after the presiding officer notifies the appointing authority. The presiding officer of the group must promptly notify the appointing authority of any member who has been automatically removed and must explain any known extenuating circumstances. The presiding officer should send a copy of the notice to each member of the group.

(3) The appointing authority, on request of the affected member, may waive the removal for illness, emergency or other good cause. The appointing authority must notify the member whether a waiver has been granted.

(4) If a waiver has not been granted, the appointing authority must appoint a successor to complete the unexpired term, subject to Council confirmation if the original appointment was subject to Council confirmation.

(c) *Other causes for removal.*

(1) The appointing authority may remove a group member for:

- (A) neglect of duty;
- (B) misconduct in office;
- (C) a member’s inability to perform the duties of the office;
- (D) conduct that impairs a member from performing the duties of the office; or
- (E) violation of law.

(2) Before a member is removed, the appointing authority must:

- (A) notify the member in writing of the reason for removal; and
- (B) give the member an opportunity to submit reasons why the member should not be removed.

(3) If any other provision of law requires the Council’s approval before a member is removed, that provision applies to a removal under this Section.

(4) If Council approval is not required before a member is removed, the appointing authority must notify the Council before the removal takes effect.

(d) Each member of a group must complete training on the Maryland Open Meetings Act, basic parliamentary procedure, and the Montgomery County Public Ethics Law. The Executive must establish standards for this training by method 2 regulation. (1979 L.M.C., ch. 22, § 1; FY 1991 L.M.C., ch. 9, § 1; [2005 L.M.C., ch. 23](#), § 1; [2016 L.M.C., ch. 11](#), § 1; [2022 L.M.C., ch. 33](#), §1.)

Editor’s note—See County Attorney Opinion dated [11/5/92](#) explaining that statutes authorizing removal of appointed officials should be read narrowly, and absenteeism requirement should not apply to subcommittee meetings. See County Attorney Opinion dated [7/22/92](#) indicating that members of Adult Guardianship Review Board may serve unlimited terms.

Sec. 2-149. Procedures at meetings.

Unless a group meeting is subject to Chapter 2A, a meeting may be conducted informally. The parliamentary procedures of Robert's Rules of Order govern when it is necessary to take formal action or decide controversial matters. Group meetings must be open to the public in accordance with the state open meetings law. (1979 L.M.C., ch. 22, § 1; FY 1991, L.M.C., ch. 9, § 1; [2016 L.M.C., ch. 11](#), § 1.)

Sec. 2-149A. Open meetings – supplemental requirements.

(a) *Open Meetings Act – additional requirements.* A group must comply with the requirements under this section, in addition to the requirements under the state Open Meetings Act, Title 3 of the General Provisions Article of the Maryland Code, as amended.

(b) *Notices of meetings.*

(1) Except as provided under paragraph (3), a group must publish the notice required under Section 3-302 of the Open Meetings Act:

- (A) within 5 business days after the group has determined the meeting date; and
 - (B) at least 2 calendar days before the meeting.
- (2) If a meeting will include virtual access, the group must publish how the public may attend the meeting virtually.
- (3) If the requirements of paragraph (1) cannot be met due to an emergency, a group must:
- (A) publish the notice at least 24 hours in advance of the meeting; and
 - (B) indicate in the notice that the meeting is an emergency meeting.
- (c) *Meeting agendas.*
- (1) Except as provided under paragraph (2), a group must publish the agenda of a meeting under Section 3-302.1 of the Open Meetings Act:
- (A) within 5 business days after the group has determined the agenda; and
 - (B) at least 2 calendar days before the meeting.
- (2) If the requirements of paragraph (1) cannot be met due to an emergency, a group must:
- (A) publish the agenda at least 24 hours in advance of the meeting; and
 - (B) indicate on the agenda that the meeting is an emergency meeting.
- (3) If the requirements of paragraph (2) cannot be met due to an emergency declared by the Governor of Maryland or the County Executive, a group must:
- (A) publish the agenda as soon as practicable in advance of the meeting; and
 - (B) indicate on the agenda that the meeting is an emergency meeting.
- (d) *Meeting minutes and recordings.*
- (1) Within 5 business days after it meets, a group must publish, if the group recorded the full meeting, a file of the recording, or a link to the recording.
- (2) Within 5 business days after approving meeting minutes, a group must publish the approved minutes under Section 3-306 of the Open Meetings Act.
- (e) *Compliance and reporting requirements.*
- (1) The County department or office assigned to staff a group must ensure the group's compliance with the requirements of this section.
- (2) A group member, or member of the public, may complain to an office or department designated by the County Executive if a group does not comply with the requirements of this section.
- (3) The designated office or department:
- (A) may consult with the group, and staff assigned to the group, to address compliance issues under this section; and
 - (B) must report in writing to the Council, on a quarterly basis, regarding complaints received under this section and the resolutions of those complaints.
- (4) Nothing in this Section prevents an individual from submitting a complaint to the state Open Meetings Compliance Board under the state Open Meetings Act, Title 3 of the General Provisions Article of the Maryland Code, as amended. ([2023 L.M.C., ch. 9](#), §1.)

Montgomery County Boards, Committees, and Commissions Policies and Procedures

- [Policies and Procedures](#)
 - [Purpose and Introduction](#)
 - [Appointment Process](#)
 - [Guidelines for Committee Operation](#)
 - [Administration](#)
 - [Advocacy Request Form](#)
-

Purpose/Introduction

Public participation in boards, committees, and commissions contributes to the work of County government and provides a valuable service to the community by presenting the concerns and viewpoints of County residents on a variety of issues. The purpose of this information is to familiarize these participants with Montgomery County's policies and procedures as they relate to service on County committees.

The policies and procedures shown here apply to members of the boards, committees and commissions listed on this site.

Appointment Process

Most committees have members who are appointed by the County Executive and confirmed by the County Council, although some committees are appointed by the Council. Committees appointed by the County Council include the Montgomery County Planning Board, the Board of Appeals, and the Merit System Protection Board. Six of the eleven members of the Charter Review Commission are also appointed by the Council.

Applications for membership on all County committees are solicited through press releases to the news media, advertisements on Montgomery County Cable Channel 6, and mailings to umbrella civic associations and community groups that have requested them. Individuals may be on the mailing list maintained by the offices of the County Executive. Notices of vacancies are posted in the government centers and libraries. Press releases describe the duties of the committee for which membership is being solicited, outline special requirements for membership, request a resume including home address and home and office phone numbers, and include a deadline for application. Applicants respond to requests for membership by submitting a letter and resume to the appointing authority indicating interest in serving on a specific committee.

The Council will not consider applications received after an announced deadline for positions on Council-appointed Boards, Committees, and Commissions. However, if a majority of Councilmembers agree to consider late applications, then the time period for receipt of applications will be reopened for all applicants and the deadline for applications will be extended.

In making appointments the appointing authority considers the following: diversity of background and professions; relevant experience and expertise; and geographic, gender and ethnic balance. Some committees have special qualifications (profession, organization membership, etc.) for some or all members. The selection process may include interviews by the County Executive or his designees and/or by the County Council. In the case of appointments made by the County Executive, the names of those selected to serve on a committee are forwarded to the Council for confirmation. When an appointment has been approved by a majority of the Council, the individual receives notice of appointment by mail. The applications and resumes of those who are appointed become public documents.

The length of appointment may vary. Most committees have a standard term of three years. It is generally intended that terms be staggered to allow for continuity. To promote participation, Council policy is that no individual should serve more than two consecutive full terms or serve on more than one committee at any one time, unless two-thirds of the Councilmembers voting grant a waiver and confirm the appointment.

When applying for reappointment, members need to indicate their current employment in their letter of application.

Financial disclosure statements will be required by applicants, in some instances.

Guidelines for Committee Operation

The purpose, membership, and function of each committee is outlined in the law, resolution, or executive order which establishes it. Some boards, committees and commissions are created by County law as required by State and Federal law. The majority are initiated by County Executive and/or County Council action.

Meeting Procedure

The State Open Meetings Act applies to County committees and requires that committees give reasonable advance public notice of meetings. Meetings must be open to the public and be held in an accessible public place. Notices of upcoming meetings are published by the County Executive's Office in an official monthly schedule which is posted in County buildings and distributed to interested citizens and the press. Notice includes the date, time, and place of the meeting. If there is insufficient time to give notice in the official listing, notice of the meeting

must be posted in a public place in the building in which the meeting will be held and in either the Executive Office Building or the Council Office Building.

A committee may hold a closed session only for the reasons set forth in the State Open Meetings Act. A statement of the time, place, and purpose of the closed meeting, and a record of the vote of each member by which the meeting was closed must be included in the minutes of the next public meeting. The following reasons merit closing a meeting: discussions of a personnel matter; protection of personal privacy; acquisition of real property; business relocation or expansion; investment of public funds; marketing of public securities; obtaining legal advice; consulting about litigation; collective bargaining; public security; scholastic, licensing, or qualifying examinations; criminal investigations; other legal requirements; or preliminary discussion of procurement issues. A committee should obtain legal advice from the County Attorney's Office before closing a meeting or concluding that a committee function is not subject to the State Open Meetings Act.

How the chair is selected varies by board, committee or commission. In some cases, the members of the boards, committees or commissions elect their own leaders. In others, the County Executive and/or the County Council appoint the chair and vice chair.

The committee chair is responsible for setting the time and place of meetings and preparing agendas. Unless a committee has adopted rules of procedure or bylaws, committee meetings may be conducted informally, but the parliamentary procedures of Robert's Rules of Order govern formal actions or decisions on controversial matters. Unless specified otherwise in law, a simple majority of membership constitutes a quorum for the transaction of business. The frequency of meetings of a particular board, committee or commission may be prescribed in the legislation which creates the body.

Some committees performing quasi-judicial functions are subject to the Administrative Procedures Act which governs the processing of administrative appeals, ex parte communications, and other matters which require quasi-judicial hearings.

Minutes

The State Open Meetings Act requires public bodies to keep written minutes of all meetings for one year. The minutes should be prepared as soon as practicable and, except for minutes of a closed session, should be open to public inspection during ordinary business hours. The Chair of the committee must designate the appropriate person to record the minutes of the meetings and in the case of public minutes transmit a copy as soon as practicable to the County's Public Information Office. The original minutes should be kept in the official files of the committee. Minutes should include the names of those in attendance; the date, time, and place of the meeting; any items considered during the course of the meeting; all actions taken; and any recorded votes taken.

Reports

At least annually, each committee must report to the County Executive and County Council on the following: the committee’s functions, activities, accomplishments, plans and objectives, including recommendations for changes in committee functions. The law or resolution establishing a committee may specify the dates when reports are due or the subjects to be included in the reports. Advisory committees may also wish to testify to the County Council on issues of relevance to their committee responsibilities. Committees that are advisory to the Council and Executive should notify the Office of Intergovernmental Relations prior to presenting testimony or taking a position before other entities such as the State government.

Administration

Attendance

Unless law provides another method, a member of a committee who misses more scheduled meetings or hearings than the allowed absences, or who misses 3 consecutive meetings, is automatically removed. Allowed absences are as follows:

Number of Meetings Held in One Year	Allowed Absences
1-4	1
5-8	2
9-12	3
13-16	4
17+	5

When a member is removed through absence, the presiding officer of the committee must promptly notify the County Executive and all members of the committee, including the member being removed. The County Executive may waive the resignation for illness, emergency, or other good cause.

Compensation

If compensation is prescribed, it will be established by law, resolution, or appropriation. Members of both compensated and non-compensated boards may request reimbursement for mileage and dependent care at rates established by the County. The member submits the appropriate form and receives a check via mail when the form has been processed.

Staffing

The County Executive and County Council designate staff as liaison for committees. Generally, the role of staff is to assist in providing notice of meetings, recording minutes, transmitting meeting materials, and meeting recordkeeping requirements under supervision of their department or agency head.

Ethics

Generally, the Montgomery County Public Ethics Law prohibits committee members from participating in matters that involve an economic or fiduciary interest of the member. Committee members are also prohibited from participating in a matter that involves an economic interest of a relative. Relatives includes siblings, parents, grandparents, children, grandchildren, a spouse, a spouse's relatives and the spouses of these relatives.

The ethics law prohibits committee members from accepting or soliciting gifts from lobbyists and persons doing business with or regulated by the agency with which the committee is affiliated. A committee member must not solicit a gift while identifiable as a member of the committee unless expressly authorized to do so for the benefit of the County by the appropriate authority.

A committee member must comply with the employment provisions of the ethics law. A committee member is not required to obtain approval for employment with respect to employment held when the member was appointed if the committee member publicly disclosed the employment relationship to the appointing authorities before appointment. A committee member must not seek a contract with the County or take as a client an entity that contracts with or is regulated by the agency with which the committee member is affiliated without first referring the matter to the Ethics Commission. A committee member should not represent a person if the person's interest is adverse to that of the County without first referring the matter to the Ethics Commission.

A committee member must not disclose confidential information or attempt to use the prestige of the member's office for private gain or the gain of another. A committee member must not use an official County agency title or insignia in connection with any private enterprise or use a County facility or property for personal use or the use of another unless the use is generally available to the public.

This description of the public ethics law is intended to provide a general overview only. In specific cases, the ethics law itself should be consulted and, where appropriate, a request for an advisory opinion or waiver made to the Ethics Commission.

Committee chairpersons are responsible for reviewing County Ethics law periodically with committee membership. Each committee member has a responsibility to adhere to the County's sexual harassment and non-discrimination policies.

Liability

Committee members have liability protection under the Local Government Tort Claims Act for actions arising out of their scope of employ, i.e. their committee responsibilities. Committee members will also receive certain medical benefits; this coverage is limited, however, to benefits for reasonable medical treatment comparable to medical benefits payable under the Maryland Workers' Compensation Act. Members must be registered with the County's Risk Management System. Committee members should ask staff for the appropriate form.

Concerns

Concerns about the functioning of committees or their staffing should be addressed to the committee chair and/or to the head of the department which provides staff support for the committee, the County Executive's Special Assistant responsible for Boards, Committees, and Commissions, or to the President of the County Council.

Boards, Committees, and Commissions

Staff and Chair Responsibilities

STAFF

- Maintain Membership Lists (including term beginning and end dates and position types)
- Keep Member Attendance Records
- Reserve County Meeting Space
- Attend Board and Committee Meetings
- Schedule Annual Planning Retreat
- Transit Meeting Materials to Members
- Oversee Member Financial Disclosure Compliance, if relevant
- Process Member Reimbursement Forms
- Provide Member Orientation
- Control/Order any Material with County Logo (e.g. letterhead)
- Ensure Compliance with County Ethics Law
- Ensure Compliance with other County Practices and Procedures and other Departments with Oversight (e.g. ADA, Office of Intergovernmental Relations, Public Information Office)
- Ensure Compliance with State Open Meetings Act (e.g. ensuring that minutes are completed, providing calendar of board meetings to County Executive staff)
- Advise County Executive Staff of Member Change of Address, Employment, etc.
- Post Agendas, Minutes and Correspondence on Website and Send Minutes to County Executive Staff

CHAIR

- Set Meeting Dates in Compliance with Enabling Legislation
- Set Meeting Agendas
- Coordinate Subcommittees
- Preside over Full Board Meetings
- Coordinates the Development of Positions via Letters

SHARED

- Record and Distribute Minutes
- Ensure Board Stays on Mission in Compliance with Enabling Legislation
- Ensure Compliance with Roberts Rules of Order on Formal Matters
- Monitor and Enforce Attendance Policy – Sending/Signing Attendance Violation Notice Letters

Boards, Committees, and Commissions

Best Practices – Preparing Minutes

1. Always include date, place, members present, members absent, time called to order. Time adjourned, action taken (who made the motion and seconded it and what the vote was) and any follow-up needed.
2. The Open Meetings Act is very general about minutes but stipulates that minutes must reflect each topic discussed, the action taken, and each vote. Each word spoken does not need to be included, nor does the Act require a synopsis of what was said.
3. Keep minutes as brief as possible. Summary minutes are desirable.
4. If a meeting or part of a meeting is closed, minutes must include a statement of the time, place, and purpose of the closed session, a record of the vote to close the session, a citation of the authority for closing the meeting, a list of the topics discussed, persons present, and each action taken.
5. Bolding motions made or action items that require follow-up might be helpful to your B/C/C members.
6. Remember that with no quorum—there is no meeting. With fewer than a quorum, the b/c/c cannot act (A quorum is a simple majority of voting members).
7. Hard copies of approved minutes should be sent to the Public Information Office (PIO) c/o Karen Falcon, 101 Monroe Street, 4th Floor, Rockville, MD 20850. Minutes will be retained by PIO for one year. Also send to the Special Assistant to the County Executive, Connie Latham by hard copy or by email to Beth Gochrach, beth.gochrach@montgomerycountymd.gov.
8. If there is a PowerPoint presentation made, it can be referenced in the minutes and a copy of the presentation can be added as part of the minutes or an addendum to the minutes.
9. When listing the members present, for ex-officio members include agency or organization represented in parentheses.
10. When using an acronym, spell out the first time used and then use the acronym in parentheses or include a list at the bottom of the minutes for easy reference.
11. Minutes and any tape recordings are required to be maintained for at least one year after a meeting.
12. Meeting Sign-in Sheet: Include the following language on your BCC's meeting sign-in sheet: "Please note that by signing this sheet, your name will become public information, recorded in the minutes of [today's/tonight's] [name of board] meeting, which may be photocopied and disseminated to various groups, and may appear on the internet and become retrievable by internet search engines."

Open Meetings Act

Office of the County Attorney

I. Open Meetings Act--General Overview; Purpose

- A. The Open Meetings Act is a state law that generally requires a public body to meet in open session.
- B. The General Assembly has found that it is essential to the maintenance of a democratic society that (except in special circumstances) public business be performed in an open and public manner. The General Assembly has declared that it is the public policy of the State of Maryland that adequate notice of the time and location of meetings of public bodies be given and that meetings be held in places reasonably accessible to individuals who would like to attend these meetings.

II. Critical Definitions

- A. A public body means an entity that consists of at least two individuals and that is created by state statute; a county charter; a county law; a rule, resolution, or bylaw; or an executive order of the chief executive authority of a political subdivision of the state.
- B. Therefore, a committee chair may create a subcommittee that will not be subject to the Open Meetings Act because the subcommittee is not created by rule, resolution, bylaw, county statute, or executive order.
- C. Meet means to convene a quorum of a public body for the consideration or transaction of public business. *↳ can include people over skype or phone call*
- D. Therefore, less than a quorum of a public body may meet to discuss public business. *E.g.*, a meeting of 3 members of a 7 member public body to discuss public business is not subject to the Open Meetings Act.
- E. E-mailing fellow members of a committee does not constitute a meeting. But, creating a "chat room" that permits real time concurrent communication may constitute a meeting.¹ *↳ or conference call*

III. Applicability

¹ An electronically stored e-mail message or a hard copy of the message in the custody and control of a public official may be subject to disclosure under the Public Information Act if the message is related to the conduct of public business.

- A. The Open Meetings Act does not apply to a public body when it is carrying out (1) an executive function; or (2) a quasi judicial function unless the public body is granting a license; a permit; a special exception; a variance; or addressing any zoning matter.
- B. The Open Meetings Act does not apply to a public body that meets by chance encounter; at a social gathering or other occasion that is not intended to circumvent the Open Meetings Act.
- C. Therefore, a public body may hold a retreat for purposes of team-building so long as the retreat is not used to discuss or transact public business. And a public body may meet in a closed session without complying with the Open Meetings Act if the body is performing an executive function. For example, the Ethics Commission performs an executive function when it meets to consider outside employment requests.

IV. Notices of Meetings

- A. Before meeting in a closed or open session, a public body must give reasonable advance notice of the session.
- B. Whenever reasonable, the notice must be in writing, include the date, time, and place of the session, and if appropriate, include a statement that a part or all of a meeting may be conducted in closed session.
- C. A public body may give notice by posting or depositing the notice at a convenient public location at or near the place of the session if the public body previously has given public notice that this method will be used. In the alternative, the public body may use any other reasonable method to give public notice.

V. Attendance at Open Sessions

- A. The general public is entitled to attend an open session.
- B. A public body may adopt and enforce reasonable rules regarding the conduct of persons attending its meetings, including the recording or broadcasting of a meeting. *you can ask people to leave the room*
- C. A member of the public does not have the right to participate in the meeting. The presiding officer may order the removal of an individual who disrupts a meeting.

VI. Closed Sessions Permitted

- A. A public body may meet in closed session only to:
1. discuss the appointment or evaluation of an employee or official over whom the public body has jurisdiction or any other personnel matter that affects one or more specific individuals;
 2. consider the acquisition of real property for a public purpose and matters directly related thereto;
 3. consider a matter that concerns the proposal for a business to locate, expand, or remain in the state;
 4. consult with counsel to obtain legal advice;
 5. consult with staff, consultants, or other individuals about pending or potential litigation;
is county attorney
 6. discuss public security if the public body determines the public discussion would constitute a risk to the public or to public security, including the deployment of fire and police services, or the development and implementation of emergency plans; and
 7. discuss a matter directly related to a negotiating strategy or the contents of a bid or proposal if public disclosure would adversely impact the ability of the public body to participate in the competitive bidding or proposal process.
- B. The public body that meets in closed session may not discuss or act on any matter not permitted for closing a session under the Open Meetings Act.
- C. A majority of the members of a public body must vote in favor of closing the session.
- D. Before a public body meets in a closed session, the presiding officer must (1) conduct a recorded vote on the closed session; (2) make a written statement of the reasons for closing the meeting, including a citation of the authority under the Open Meetings Act for closing the session and list the topics to be discussed; and (3) (if a person objects to the closing of a session) send a copy of the written statement to the Open Meetings Compliance Board.

VII. Minutes

- A. As soon as practicable after a public body meets, the public body must prepare written minutes of its session.
- B. Minutes must reflect each item the public body considered, the action that the public body took on each item, and each vote that was recorded.
- C. If a public body meets in closed session, the minutes for its next open session must include:
 - 1. a statement of the time, place, and purpose of the closed session;
 - 2. a record of the vote of each member as to closing the session;
 - 3. a citation of the authority under the Open Meetings Act for closing the session; and
 - 4. a listing of the topics of discussion, persons present, and each action taken during the session.
- D. A public body must preserve for one year its minutes and any tape of a recording of its closed sessions.

VIII. Penalty

A member of a public body who willfully participates in a meeting of the body with knowledge that the meeting is being held in violation of the provisions of the Open Meetings Act is subject to a civil penalty not to exceed \$100.

IX. Other Enforcement Provisions

Upon a complaint by a person adversely affected by a public body that fails to comply with the Open Meetings Act, a court may require the public body to comply with the act or void the action of the public body. The court may award the prevailing party reasonable attorney's fees and other litigation expenses.

X. Compliance Checklist

The Office of the Attorney General has drafted a compliance checklist and a form statement for closing a meeting. A copy is attached. A current copy of these documents may be obtained at <http://www.oag.state.md.us/>.

COMPLIANCE CHECKLIST

For *all meetings* covered by the Act, did you:

- A. Provide proper advance notice?
- B. Arrange for minutes to be taken?

For *closed meetings* covered by the Act, did you also:

- A. Identify one or more of the following grounds for closing the meeting?*
1. a specific personnel matter;
 2. protection of personal privacy on a matter unrelated to public business;
 3. acquisition of real property;
 4. a proposed business relocation or expansion;
 5. the investment of public funds;
 6. the marketing of public securities;
 7. obtaining legal advice;
 8. consulting about litigation;
 9. collective bargaining;
 10. public security;
 11. scholastic, licensing, or qualifying examinations;

* These items are merely synopses of the exceptions. The actual text of an exception should be considered carefully before a meeting is closed on that basis.

Compliance Checklist

12. criminal investigations;
 13. other legal requirement; or
 14. preliminary discussion of procurement issues.
- B. Record a majority vote in favor of closing the meeting?
- C. Prepare, at the time of the vote, a written statement of the reasons and legal basis for closing the meeting and the topics to be discussed?
- D. Keep the closed-session discussion within the scope of the exception that you cited?
- E. Include in the minutes of the next open meeting a statement of the time, place, and purpose of the closed meeting; a record of the vote to close the meeting and the authority to do so; and a listing of the topics discussed, the persons present, and the actions taken?

For a meeting *recessed into closed session to conduct an administrative function*, did you include in the minutes of the next open meeting a statement of the date, time, place, and persons present and a phrase or sentence identifying the subject matter discussed at the closed session?

After a meeting, did you file and maintain records in accordance with the record retention requirements of the Act?

Revised October 2006

MONTGOMERY COUNTY PUBLIC ETHICS LAW—OUTLINE

Marc P. Hansen
Edward B. Lattner
Office of the County Attorney

- I. Introductory Remarks; Disclosure
 - A. This is a general overview of the Montgomery County Public Ethics Law.
 - B. Under the County's ethics law, the County Ethics Commission is the only administrative agency authorized to provide a public employee with definitive advice concerning the applicability of the ethics law to a particular situation.
 - C. In specific cases, you should consult with your agency counsel or the Ethics Commission staff and, where appropriate, you may request an advisory opinion or waiver directly from the Ethics Commission.
- II. Purpose of the Montgomery County Public Ethics Law
 - A. Maintain a high degree of trust that public officials will use impartial and independent judgment when conducting public business.
 - B. Guard against improper influence affecting the decision making process of public officials.
 - C. State law requires every county to have a public ethics law "substantially similar" to the state's public ethics law in three areas: conflicts, financial disclosure, and lobbying.
- III. Applicability
 - A. The ethics law applies to all "public employees".
 - B. By definition, public employees include members of boards, commissions, committees, task forces, or similar bodies, whether the member is paid or unpaid.
 - C. In this presentation, references to employees includes members of County boards, committees, or commissions whether the member is paid or unpaid for her or his services.
- IV. Participation of Employees in Matters.
 - A. 19A-11(a). A public employee must not participate in a matter that affects, in a manner distinct from its effect on the public generally, any property or business in which the public employee or a "relative" of the public employee has an

“economic interest.”¹ The public employee must know about the relative’s economic interest.

- B. 19A-11(b). A public employee must not participate in a matter if the member knows (or reasonably should know) that any of the following is a party to the matter:
1. any entity of which the employee is an officer, director, trustee, partner, or employee.
 2. any entity in which a relative of the employee has an economic interest, if the employee knows about the interest;
 3. any business with which the employee is negotiating or has an arrangement about employment;
 4. any business that is negotiating with a relative of the employee about prospective employment, if the employee knows about the arrangement;
 5. any entity or individual that is a party to an existing contract with the employee or a relative of the employee, if the contract could reasonably result in a conflict between the employee’s private interest and official duty;
 6. any business in which the employee has an indirect economic interest, if the employee could reasonably be expected to know of the indirect interest; and
 7. any creditor or debtor of the employee or relative, if the creditor or debtor can directly and substantially effect an economic interest of the member or relative.
- C. 19A-12(b). An employee may not own more than 1% of any business that:
1. is regulated by the County agency with which the employee is affiliated;
or
 2. negotiates or contracts with the County agency with which the employee is affiliated; and
- D. Identifying the agency with which a member of a committee is affiliated must be decided on a case by case basis. The Ethics Commission has yet to determine

¹ The ethics law defines the term relative in a very broad manner. Relative means: (1) the employee’s siblings, parents, grandparents, children, and grandchildren; (2) the employee’s spouse or domestic partner and the spouse’s or domestic partner’s siblings, parents, grandparents, children, and grandchildren; and (3) the spouses of these relatives. For a definition of economic interest see paragraph E *infra*.

what the phrase “agency with which the employee is affiliated” means in the context of the 1% rule. But the Ethics Commission has ruled that a citizen member of a quasi-judicial board is not affiliated with its “parent” agency just because that agency provides the board with staff support.² The Ethics Commission has concluded that the agency of the members of the following quasi-judicial boards is only the board itself:

1. Animal Matters Hearing Board;
2. Board of Appeals;
3. voting members of the Board of Electrical Examiners;
4. Board of Registration;
5. Commission on Landlord-Tenant Affairs;
6. voting members of the Commission on Common Ownership Communities;
7. Fire Rescue Commission, except that career firefighter and volunteer firefighter’s agencies include their respective departments;
8. Case Review Board of the Human Rights Commission;
9. Merit System Protection Board;
10. Sign Review Board; and
11. Historic Preservation Commission.

E. An economic interest must exceed one of the following thresholds in order for the interest to trigger a conflict of interest under the ethics law:

1. source of income exceeds \$1,000/year;
2. ownership interest exceeds 3% of the business; or
3. any other economic interest worth more than \$1,000.

V. Outside Employment

² *Advisory Opinion No. 03-014. But see Advisory Opinion 02-013* (Mental Health Advisory Committee is affiliated with DHHS because it performs a watchdog function over DHHS-provided services).

- A. 19A-12. Generally, a public employee must not engage in any outside employment unless the employment is approved by the Ethics Commission.
- B. 19A-12(b). Unless the Ethics Commission grants a waiver, an employee must not be employed by (1) any business that is regulated by the County agency with which the employee is affiliated; (2) by a business seeking or doing business with the County agency with which the employee is affiliated; or (3) hold any employment relationship that could reasonably be expected to impair the impartiality and independence of judgment of the employee.
- C. A member of a committee is not required to obtain approval for outside employment with respect to employment held when the member was appointed to the body. But, the member must publicly disclose the employment relationship before appointment to the appointing authority and to the County Council when confirmation is required.
- D. A compensated³ member who subsequently changes employment must obtain Ethics Commission approval. A self-employed employee may acquire new clients without obtaining prior approval of the Ethics Commission. But, a member who intends to contract with the County or take a client that is subject to the authority of or contracts with the agency with which the employee is affiliated should first refer the matter to the Ethics Commission for approval.
- E. An employee who is appointed to a regulatory or licensing body under a statutory provision that a person subject to the jurisdiction of the body may be represented in appointments to it may participate in general matters that effect the member's business, but the employee should not participate in a matter that specifically and directly affects the employee's business.

VI. 19A-13. Post-County Employment

- A. A former employee member must not work on or assist any party (other than the County) in a case, contract, or other specific matter for 10 years after significantly participating in the matter.

But the Commission has narrowly interpreted § 19A-13(a), given its proscription against working on the same "specific matter" and its relatively harsh 10-year prohibition. *See Advisory Opinion 03-015* (former county employee could work for company conducting inventory of bus stops although duties as a public employee included planning bus service, recommending route changes, and community outreach); *Advisory Opinion 03-016* (former County employee could perform accounting work for company although duties as a public employee included budget work).

³ See Ethics Commission Regulation # 25-01, Section 4.12.

- B. For one year after termination of employment with the County, a former employee must not enter into any employment relationship with any person or business if the employee “significantly participated”⁴ during the previous 3 years:
 - 1. in regulating the person or business; or
 - 2. in any procurement or other contractual activity concerning a contract with the person or business.
- C. The applicability of this provision to unpaid members of committees is uncertain, because the term “employment” is defined in the law as “engaging in an activity for compensation”. The Ethics Commission has not yet been asked to decide this issue.

VII. 19A-16(c) through (f). Accepting Gifts

- A. An employee must not accept a gift from a person if the employee knows or reasonably should know that the person:
 - 1. is a lobbyist on a matter that is or could be considered by the agency with which the employee is affiliated;
 - 2. does business with the employee’s agency;
 - 3. owns or operates a business regulated by the employee’s agency; or
 - 4. has an economic interest the employee could substantially affect.
- B. An employee may accept the following gifts from one of the above “interested persons”:
 - 1. any item that is solely of an informational or an advertising nature, including a book or pamphlet, if the resale value of the item is \$25 or less;
 - 2. meals and beverages from the same person under \$50 per year;
 - 3. ceremonial gifts or awards with a resale value of \$100 or less if the gift or award commemorates an event or achievement associated with the employee/member;
 - 4. personal property valued at under \$10 (but not cash);

⁴ Significant participation means making a decision, rendering advice, investigating, or taking similar action as a public employee. It ordinarily does not include program oversight or budget preparation or approval.

5. reasonable expenses for food, lodging, travel, and scheduled entertainment in exchange for the employee/member's participating on a panel or speaking at a meeting;
 6. gifts from a relative; and
 7. honoraria or awards for achievement;
- C. If an employee receives a gift prohibited by the ethics law, the employee must report the gift to the Ethics Commission and:
1. return the gift; or
 2. transfer the gift to the County.

VIII. 19A-16(a) & (b). Soliciting Gifts

- A. An employee must not solicit a gift to the employee or another person or organization from any business or person who:
1. is registered or must register as a lobbyist;
 2. does business with the County agency with which the employee is affiliated; or
 3. is or owns or operates a business that is regulated by the County agency with which the employee is affiliated.
- B. An employee must not solicit a gift at a County agency (facility), during "official work" hours (unlikely to apply to members of a committee), or from another employee who is supervised "directly or indirectly" by the employee.
- C. An employee must not solicit a gift while wearing a County uniform or while otherwise identifiable as a public employee.
- D. An employee must not solicit a gift with the intent of affecting or offering to affect any action by a County agency.
- E. An employee may solicit gifts for a charitable organization if the employee does not primarily solicit from those persons or entities doing business with or regulated by the employee's agency.
- F. An employee may solicit a gift for the benefit of the County if the solicitation is authorized by an Executive Order (or for those committees in the legislative branch of government by the County Council).

IX. Other Regulated Conduct

- A. 19A-15(a). An employee must not disclose confidential information.
- B. 19A-15(b). An employee must not consider private or ex parte communications regarding any matter that must be decided on the basis of a hearing record.
- C. 19A-14(a). An employee must not use the prestige of the employee's office for private gain or the gain of another.
- D. 19A-14(b). Unless authorized by the Chief Administrative Officer, an employee must not use an official county agency title or insignia in connection with any private enterprise.
- E. 19A-14(c). An employee must not use any County facility or property for personal use or the use of another unless the use is generally available to the public.
- F. 19A-14(g). A public employee must not with respect to a particular matter represent another person or provide advice to another person that would qualify as an expert opinion in a court, if:
 - 1. a County agency or the County is a party to the matter and the person being assisted has a position adverse to the County; or
 - 2. the County agency or the County has a direct and substantial interest in the matter that is adverse to the interest of the person being assisted;
 - 3. this provision does not apply to a member of a committee if:
 - a. the member is not compensated by the County; and
 - b. the matter does not relate to the responsibilities of the employee;
 - 4. this provision does not apply to an employee who renders assistance to a member of the employee's immediate family if the employee renders the assistance without compensation.
- G. 19A-16A. A member of a quasi-judicial board must not solicit or accept from a person within the board's jurisdiction a financial contribution for any political candidate, political organization, or ballot question (other than a ballot question which directly affects the employee's agency); or solicit from a person within the board's jurisdiction an endorsement of or opposition to a political candidate.

X. Financial Disclosure

- A. A member must file an annual financial disclosure statement if required to do so by ethics law or regulation (in some cases by Council resolution).
 - B. Failure to file may lead to:
 - 1. removal
 - 2. civil citation (fine and injunction to file).
 - C. Attribution rules apply. Carefully read form's instructions.
 - D. Filer must disclose certain economic interests including:
 - 1. business interests including stocks and mutual funds
 - 2. debts owed and due you
 - 3. real property holdings in certain counties
 - 4. sources of income
 - 5. certain gifts
 - E. Most interests only require disclosure of a range of values, not actual value. For example, \$1000 or less, over \$1000.
 - F. Filing is under oath and subject to perjury.
 - G. Filing may be public, confidential, or confidential with limited public disclosure.
- XI. Advisory Opinions.
- A. Any person subject to the ethics law may ask the Ethics Commission for an advisory opinion on the meaning or application of the law to that person.
- XII. Waiver
- A. Upon receiving a written request, the Commission may grant an employee or a class of employees a waiver from the prohibitions of the ethics law.
 - B. In order to grant a waiver, the Commission must find:
 - 1. the best interest of the County would be served by granting the waiver;
 - 2. the importance to the County of the employee performing his/her official duties outweighs the actual or potential harm of any conflict; and

3. granting the waiver will not give the employee an unfair advantage over the public.
- C. In reviewing a waiver request to allow a member to work for a business which contracts with, or is regulated by, the employee's agency, the Ethics Commission must determine whether:
1. the waiver is needed to ensure that competent services are made available to the County;
 2. failure to grant the waiver may reduce the ability of the County to hire or retain highly qualified employees; or
 3. the proposed employment is not likely to create an actual conflict of interest.

XIII. Complaints and Investigations

- A. Any person may file a complaint with the Ethics Commission. The complaint must allege facts that if true would constitute a violation of the ethics law.
- B. The Commission may investigate any matter that the Commission believes may constitute a violation of the ethics law or after receiving a complaint.
- C. The Commission has the authority to adjudicate a violation of the ethics law.
- D. The Ethics Commission may impose or recommend the imposition of sanctions for violations of the ethics law.

XIV. Penalties

- A. Class A violation (Criminal: \$1000 fine, 6 months in jail; or \$500 civil fine);
- B. Recover damages;
- C. Impose discipline, including terminating employment, of a public employee;
- D. Suspend compensation until employee complies with a commission order.

MONTGOMERY COUNTY PUBLIC ETHICS LAW—TRAINING (bcc)
Hypothetical Cases

Marc P. Hansen
Edward B. Lattner
Office of the County Attorney

Participation Of Public Employees In Matters

- I. J. Caesar is a member of the Committee on Children and Youth. The Committee is responsible for providing advice to the Department of Health and Human Services (DHHS) regarding the funding and implementation of DHHS programs designed to support children, youth and families. Mr. Caesar's sister, Calpurnia, owns and operates a business that provides child care. Calpurnia accepts clients who pay for child care services with a County voucher. DHHS issues County vouchers to income qualified parents of children. At Mr. Caesar's first committee meeting the chair announces that the first item on the agenda is to provide advice to DHHS regarding the adequacy of the funding level of the County voucher program.
- A. Is Mr. Caesar subject to the County ethics law?
 - B. Must Mr. Caesar take his sister's business into account before participating in the Committee's discussion on the appropriate funding level for the County voucher program?
 - C. Does it make any difference that Calpurnia's business is only worth \$500?
 - D. Does the ethics law prohibit Mr. Caesar from participating in the Committee's discussion on the appropriate funding level for the County voucher program?
- II. Ms. Elizabeth Tudor is a member of the Board of Directors for England Estates. England Estates is an exclusive common ownership community that imposes strict regulations concerning the appearance of homes in the association. Ms. Tudor has been appointed to the Commission on Common Ownership Communities (COCOC). Ms. Tudor does not receive compensation for performing the duties of either position. Mary Stuart, a resident of England Estates, has filed a complaint against England Estates with COCOC, because England Estates refuses to permit her to paint her front door royal blue. Ms. Tudor is assigned to a panel charged with responsibility for adjudicating this complaint.
- A. Does the ethics law prohibit Ms. Tudor from participating in this matter?
 - B. Would it make a difference if the case involved Scotland Estates instead of England Estates?

Secondary Employment

- III. Mr. T. A. Edison serves as a member of the Cable Communication Advisory Committee (CCAC). Mr. Edison's recently deceased uncle, B. Franklin, has left Mr. Edison 1000 shares of IBM stock with a current market value of \$100,000. The staff at the Department of Housing and Community Affairs (DHCA) provides staff support to the CCAC. DHCA has a consulting contract with IBM to design a software program to track consumer complaints against the cable franchise holder.
- A. Does the ethics law require Mr. Edison to choose between accepting his inheritance or continuing as a member of the CCAC?
- B. Would the answer differ if Mr. Edison was a paid employee of DHCA?
- IV. Mr. A. Lincoln is a member of the Merit System Protection Board. The position is paid. At the time he was appointed to the Merit Board he disclosed that he was an attorney engaged in the private practice of law. Mr. Lincoln has now decided to leave the practice of law and accept employment with the United States.
- A. Does Mr. Lincoln need to obtain the permission of the Ethics Commission?
- B. Would it make any difference if Mr. Lincoln were a member of the Commission on Landlord Tenant Affairs (whose members are unpaid)?

Post-County Employment

- V. Mr. T. Roosevelt has just received an offer of employment from a cable communication provider that holds a cable communication franchise from Montgomery County. Until his term expired last week, Mr. Roosevelt was a member of the Cable Communications Advisory Committee and had participated in discussions on whether Montgomery County should renew the franchise of the cable company that had just offered him employment. Mr. Roosevelt's job for the cable company would involve acting as liaison between the cable company and the Montgomery County Government.
- A. Does the County ethics law prohibit Mr. Roosevelt from accepting this employment offer?
- B. Does it matter under the Ethics law whether Mr. Roosevelt had vehemently opposed renewing the franchise with the cable company that has just offered him employment?
- C. Would it matter if the cable company wanted to hire Mr. Roosevelt to act as a liaison between the cable company and Fairfax County?

Accepting Gifts

- VI. Ms. A. Adams is a member of the Fire & Rescue Commission. Mr. T. Jefferson, who is president of a local fire and rescue department (LFRD), has invited Ms. Adams to a banquet where the LFRD proposes to present Ms. Adams with a plaque for her 30 years of service as a Montgomery County Public School teacher. The Fire and Rescue Commission is currently considering adoption of a regulation that governs the conduct of volunteer fire fighters.
- A. May Ms. Adams accept the invitation to the banquet?
- B. May Ms. Adams accept the ceremonial plaque?

Soliciting Gifts

- VII. T.J. Hooker is shift supervisor in the Police Department. He is trying to help his son's high school baseball team raise money to go to the National Baseball Hall of Fame in Cooperstown, NY.
- A. Does the ethics law prohibit Officer Hooker from approaching employees he supervises for a donation to support his son's team?
- B. Does the ethics law prohibit Officer Hooker from going door-to-door in his neighborhood soliciting donations while he is wearing his police uniform?
- C. The Department has a \$10,000 contract with Office Depot for office equipment. Does the ethics law prohibit Officer Hooker from approaching Office Depot for a donation to support his son's team if he goes after work and not identifiable as a public employee?
- D. Would it make any difference if Officer Hooker had decided to solicit this donation for the Red Cross, a charitable organization, after work and while not identifiable as a public employee?
- E. Due to significant budget cutbacks, the Police Chief has asked Officer Hooker to approach local merchants, while on duty and in uniform, for donations to support the County Police Department. Can he do this?

Prestige of Office

- VIII. Mr. N. Bonaparte is a member of the County's Consumer Affairs Advisory Committee. Mr. Bonaparte owns a car dealership in Silver Spring. He has recently aired a television commercial in which he prominently explains that as a member of the Montgomery County Consumer Affairs Committee he understands how important it is to give consumers a square deal. Has Mr. Bonaparte violated the County ethics law?

Financial Disclosure

- IX. Ms. A. Rockefeller is a member of the Montgomery County Board of Appeals. She is required to file a public financial disclosure statement. Does Ms. Rockefeller have to report on the financial disclosure form all of the business interests of her husband, Mr. J. Rockefeller, even if she has no control over those interests?

Procedure

- X. Mr. A. Capone is a County employee who provides staff support to the Board of License Commissioners. The Board of License Commissioners is meeting to consider whether to grant a liquor license to Ms. M.A. Baker. To Mr. Capone's surprise, Mr. M.G. Kelley, who is a member of the Board of License Commissioners, votes to deny the license. Mr. Capone knows that Mr. Kelley owns a coffee shop located next door to Ms. Baker's establishment, and Mr. Capone had, therefore, expected Mr. Kelley to recuse himself from the Baker licensing matter.
- A. May Mr. Capone ask for an advisory opinion concerning the actions taken by Mr. Kelley?
- B. Can Mr. Capone file a complaint with the Ethics Commission concerning Mr. Kelley's conduct?
- C. Does the Ethics Law require Mr. Capone to file a complaint against Mr. Kelley?

I:\KQ\LATTNE\training materials\ethics training questions (EBL edit).doc

MONTGOMERY COUNTY PUBLIC ETHICS LAW—TRAINING
Answers to Hypothetical Cases

Marc P. Hansen
Edward B. Lattner
Office of the County Attorney

Participation Of Public Employees In Matters

I. The Case of Caesar's Child Care Center

- A. Mr. Caesar is subject to the County ethics law because the ethics law applies to all "public employees." A public employee includes paid and unpaid members of boards, committees, and commissions. § 19A-4(m).
- B. Mr. Caesar must take his sister's business into account before participating in the Committee's discussion on the appropriate funding level for the County voucher program. A public employee must not participate in a matter that affects a business in which the public employee or a **relative** has an **economic interest**. § 19A-11(a)(1). Relative is broadly defined; it includes siblings. § 19A-4(n).
- C. The value of Calpurnia's business is relevant because the participation rule has certain thresholds. § 19A-11(c). An economic interest only includes:
 - 1. Source of income exceeds \$1,000.00/year;
 - 2. Ownership interest exceeds 3% [that captures Calpurnia]; or
 - 3. Any other economic interest worth more than \$1,000.00.
- D. The ethics law prohibits Mr. Caesar from participating in the Committee's discussion on the appropriate funding level for the County voucher program if Caesar knows about his sister's business, because he would be participating in a matter that affects a business, in a manner distinct from its effect on the public generally, in which he knows a relative holds an economic interest.

II. The Case of the Blue Door

- A. The ethics law prohibit Ms. Tudor from participating in this matter because a public employee [Ms. Tudor] must not participate in a matter if the employee knows that any party to the matter [England Estates] is a business for which the public employee is a director—the Divided Loyalty Rule. § 19A-11(a)(2)(A).
- B. Ms. Tudor could participate if the complaint was filed against Scotland Estates because Ms. Tudor would not be participating in a matter that affects, in a manner

distinct from its effect on the public generally, any property or business in which she or a relative holds an economic interest.

Secondary Employment

III. The Case of Mr. Lincoln's New Job

- A. Mr. Lincoln needs Ethics Commission approval for his new job. A public employee must not engage in any outside employment unless the employment is approved by the Ethics Commission, § 19A-12(a)(1). This does not apply to employment held at the time of appointment, if disclosed to the appointing authority and Council, even if clients or customers later change.
- B. Mr. Lincoln would not need Ethics Commission approval if he were on COLTA because the Ethics Commission's secondary employment regulation exempts uncompensated, appointed officials from the secondary employment approval process.

IV. The Case of Edison's Dilemma

- A. Mr. Edison can continue on the CCAC and keep the stock. A public employee must not be employed by or own more than 1% of any business that is regulated by, negotiates with, or contracts with the County agency with which the employee is affiliated. § 19A-12(b). IBM contracts with DHCA, but Mr. Edison is not affiliated with DHCA. Ethics Commission has ruled that merely receiving staff support is not affiliation with an agency. *Advisory Opinion No. 03-014*. But see *Advisory Opinion 02-013* (Mental Health Advisory Committee is affiliated with DHHS because it performs a watchdog function over DHHS-provided services)
- B. Mr. Edison could remain employed by DHCA and keep the stock because, although he is now affiliated with DHCA, he is not employed by IBM and does not own more than 1% of IBM.

Post-County Employment

V. The Case of Mr. Roosevelt's New Deal

- A. Mr. Roosevelt cannot accept employment with the cable provider because a former employee must not work on or assist any party, other than the County, in a case, contract, or specific matter for 10 years after **significantly participating** in the matter. § 19A-13(a).

But the Commission has narrowly interpreted § 19A-13(a), given its proscription against working on the same "specific matter" and its relatively harsh 10-year prohibition. See *Advisory Opinion 03-015* (former county employee could work for company conducting inventory of bus stops although duties as a public

employee included planning bus service, recommending route changes, and community outreach); *Advisory Opinion 03-016* (former County employee could perform accounting work for company although duties as a public employee included budget work).

- B. Mr. Roosevelt cannot accept employment with the cable provider even if he had vehemently opposed renewing its franchise because **significant participation** means making a decision, rendering advice, investigating, or taking similar action as a public employee. It ordinarily does not include program oversight or budget review or adoption. § 19A-13(c).
- C. Mr. Roosevelt cannot accept employment with the cable provider to act as a liaison between the cable company and Fairfax County. For one year after leaving County employment, a former employee must not be employed by a person or business if the employee **significantly participated** during the previous 3 years in regulating—or in a contractual transaction with—that person or business. § 19A-13(b).

Accepting Gifts

VI. The Case of Ms. Adams' Award

- A. Ms. Adams can accept the invitation if it's worth less than \$50. General Rule: An employee must not accept a gift from a person if the employee knows that the person owns or operates a business regulated by the employee's agency. § 19A-16(c)(3). But an employee may accept a gift from an "interested person" if it is for meals and beverages from the same person under \$50 per year. § 19A-16(d)(1). Remember, just because you can doesn't mean you should.
- B. Ms. Adams can accept the ceremonial plaque. An employee may accept an award from an "interested person" that is ceremonial in nature if the resale value of the award is \$100 or less and the award commemorates an achievement associated with the employee. § 19A-16(d)(2). An employee may also accept items of personal property, other than cash, worth less than \$10. § 19A-16(d)(3). Remember, just because you can doesn't mean you should.
- C. Ms. Adams could not accept the invitation to the banquet or the award if they are offered for Ms. Adams' services on the Fire and Rescue Commission. Section 19A-14(a) provides that a public employee must not intentionally use the prestige of office for private gain or the gain of another. An employee violates that section by accepting remuneration for any service directly and immediately related to that employee's governmental activities. *Advisory Opinions 02-011, 03-010, & 03-011*.

Soliciting Gifts

VII. The Case of Officer Hooker's Good Deed

- A. The ethics law prohibits Officer Hooker from approaching employees he supervises for this donation. A public employee cannot solicit a gift to the employee or another person during work hours or from subordinates. § 19A-16(a)(2).
- B. The ethics law prohibits Officer Hooker from going door-to-door while in his police uniform. A public employee cannot solicit a gift to the employee or another person while identifiable as a public employee. § 19A-16(a)(3).
- C. The ethics law prohibits Officer Hooker from approaching Office Depot even after work hours and even if not identifiable as a public employee. A public employee must not solicit a gift from any person or business that is regulated by, or does business with, the County agency with which the employee is affiliated. § 19A-16(a)(1)(B).
- D. A public employee may solicit a gift for a charitable organization or a municipality (the County is not a municipality) if the employee does not primarily solicit from entities that are regulated by, or do business with, the County agency with which the employee is affiliated or from subordinates. § 19A-16(b)(2).
- E. A public employee may solicit a gift for the benefit of a County agency, during work hours and while identifiable as a public employee, if the solicitation is authorized by the County Executive. § 19A-16(b)(3). These executive orders typically preclude the employee from soliciting from any person or business that is regulated by, or does business with, the County agency with which the employee is affiliated.

Prestige of Office

VIII. The Case of Mr. Bonaparte's Sales Campaign

Mr. Bonaparte cannot use his public employment to advance his outside employment. An employee must not intentionally use the prestige of the employee's office for private gain or the gain of another. § 19A-14(a).

Financial Disclosure

IX. The Case of Ms. Rockefeller's Disclosure

Yes, Ms. Rockefeller must report her husband's business holdings even if she has no control over them. The financial disclosure statement requires an employee to provide various types of information regarding the holdings and debts of an **immediate family** member, which includes a spouse, regardless of whether the employee controlled that interest. One would reasonably expect a spouse to care deeply about the other spouse's holdings and debts even in

the absence of any formal ownership or control, given the obviously close and personal nature of a spousal relationship. This “caring,” in and of itself, could create a conflict of interest or be manipulated by others. This does not necessarily hold true for a public employee’s other **relatives**. Thus, a public employee must also provide some of this same information for relatives (a broader category) only if the employee (1) controlled that relative’s interest and (2) in the performance of official duties, could affect that relative’s interest. § 19A-20. *Advisory Opinion No. 03-020*.

Procedure

X. The Case of Mr. Capone’s Citizenship Challenge

- A. Mr. Capone cannot ask for an advisory opinion concerning the actions taken by Mr. Kelley. A person subject to the Ethics law may ask the Ethics Commission for an advisory opinion on the application of the Ethics law to that person. Also a supervisor can ask for an advisory opinion about a subordinate. § 19A-7(a).
- B. Mr. Capone can file a complaint with the Ethics Commission concerning Mr. Kelley’s conduct. Any person may file a complaint with the Ethics Commission. The complaint must allege facts under oath that, if true, would constitute a violation of the Ethics law. § 19A-10.
- C. The Ethics Law does not require Mr. Capone to file a complaint against Mr. Kelley. The Ethics law does not require a public employee to report a violation of the Ethics law. But § 33-10 encourages all employees to report incidents of wrongdoing. This County “Whistleblower” law protects employees from retaliation for reporting incidents of wrongdoing.

**MONTGOMERY COUNTY BCC ATTENDANCE POLICY
SAMPLE LETTER**

**From BCC Board Chair or Staff Liaison
to BCC member
regarding member attendance policy violation.**

Please also see attached pages:

- 1) Instructions for staff**
- 2) Reference to Montgomery County Code Sec. 2-148.**

Date

Dear [BCC member]:

The records of the [name of BCC] indicate that you have been unable to attend [number of meetings missed] meetings on [dates of meetings] of the [name of BCC] since [date of last meeting attended]. I know that everyone has changes in their lives that disrupt their plans and appreciate that, despite best intentions, sometimes it is impossible to attend a meeting.

An attendance policy exists in the Montgomery County Code, however, which states that: “A member of a committee who misses more scheduled meetings or hearings than the number of allowed absences, computed by the following table, or who misses 3 consecutive scheduled meetings is automatically removed. Scheduled meeting or hearing means any meeting or hearing for which at least 7 days advance notice was given and which was held as scheduled.”

Allowed Absences:

Number of Meetings Held in One Year	Allowed Absences
1-4	1
5-8	2
9-12	3
13-16	4
17+	5

If there have been extenuating circumstances, and you would like to continue to serve, please contact [BCC Staff Liaison or Board Chair] at [phone number] no later than [two weeks from date of letter]. Should we not hear from you, we will consider your position on the [name of BCC] vacated.

[Staff can add any paragraph that may be appropriate about the member’s contributions and service to the BCC].

Sincerely,

[Board Chair or Staff Liaison]

cc: Connie Latham, Special Assistant to the County Executive

MONTGOMERY COUNTY BCC ATTENDANCE POLICY INSTRUCTIONS

For Staff Liaisons

In general, staff should make all new members aware of the attendance policy at orientation, and provide timely reminders of the policy to current members.

If a member is in violation of the attendance policy, the member must be notified and allowed to respond as follows:

- 1) Send attendance letter to the member, clearly noting dates of meetings missed. Allow for a two-week response time.
- 2) Provide a copy of attendance letter to the representative of the “appointing authority,” Connie Latham, Special Assistant to the County Executive. ***This may be mailed or emailed to Beth Gochrach.***
- 3) If the member does not respond to the attendance letter in two weeks, notify the appointing authority again that the member has not responded.
- 4) Send a copy of the notification (in step 3) to each member of the committee.
- 5) Remember that for the purpose of counting absences, a year is a “rolling” year triggered by the member’s first absence and then counting back 12 months from the current month.

**MONTGOMERY COUNTY BCC ATTENDANCE POLICY
REFERENCE IN MONTGOMERY COUNTY CODE**

Montgomery County Code
Part II. Local Laws, Ordinances, Resolutions, Etc.
Chapter 2. Administration. [Note]

Article XI. Boards, Committees and Commissions. [\[Note\]](#)

Sec. 2-148. Appointments and removals.

(b) *Removal for absenteeism.*

(1) A member of a committee who misses more scheduled meetings or hearings than the number of allowed absences, computed by the following table, or who misses 3 consecutive scheduled meetings, is automatically removed. Scheduled meeting or hearing means any meeting or hearing for which at least 7 days advance notice was given and which was held as scheduled

Number of Meetings Held in One Year	Allowed Absences
1-4	1
5-8	2
9-12	3
13-16	4
17+	5

(2) An automatic removal under this subsection takes effect 30 days after the presiding officer notifies the appointing authority. The presiding officer of the committee must promptly notify the appointing authority of any member who has been automatically removed and must explain any known extenuating circumstances. The presiding officer should send a copy of the notice to each member of the committee.

(3) The appointing authority, on request of the affected member, may waive the removal for illness, emergency or other good cause. The appointing authority must notify the member whether a waiver has been granted.

(4) If a waiver has not been granted, the appointing authority must appoint a successor to complete the unexpired term, subject to Council confirmation if the original appointment was subject to Council confirmation.

Important Websites to Know

County Website

www.montgomerycountymd.gov

Boards, Committees, and Commissions

www.montgomerycountymd.gov/boards/

- Find *Policies and Procedures, B/C/C List and Brief Description, Meeting Calendar, Vacancy Notices and Online Application Procedure Council Policy Regarding Appointments*

Montgomery County Code

<https://codelibrary.amlegal.com/codes/montgomerycounty/latest/overview>

- You can also find it by going to the County's main website:
<https://www.montgomerycountymd.gov/mcg/countycode.html>
- When searching the County Code, fill in the Search Bar with the Code Section or B/C/C title

Mid-County Regional Services Office

<https://www.montgomerycountymd.gov/midcounty>

Wheaton Urban District

<https://www.wheatonmd.org/>

Mid-County Citizens Advisory Board

montgomerycountymd.gov/midcounty/boards/mccabindex.html

Wheaton Urban District Advisory Committee

montgomerycountymd.gov/midcounty/boards/wudacindex.html

Open Meetings Act

<http://www.marylandattorneygeneral.gov/Pages/OpenGov/Openmeetings>

Roberts Rules of Order

<https://robertsrules.com/frequently-asked-questions/>

Section 3:

MCCAB Structure

MID-COUNTY CITIZENS ADVISORY BOARD OPERATING PROCEDURES & MEMBERSHIP GUIDELINES

Operating Procedures

- Yearly Term** The board's yearly term runs from August 1st (or when confirmed by the County Council) to July 31st. No meeting is held in August
- Chairmanship** The board votes on a Board Chair, Vice Chair, Secretary and Parliamentarian at the July meeting. The new officers then preside over the new yearly term beginning with the September meeting. The Chair may serve no more than two consecutive years.
- Meetings** The full board meets the third Tuesday evening each month (except August). The draft agenda is emailed to each member the week prior to the monthly meeting for Board members comments and additions. A quorum consisting of nine (9) members is needed to conduct business. Committees will meet as needed between board meetings. The State Open Meetings Act requires public bodies to keep written minutes of all full board meetings.
- Committees** Each board member will serve on one committee but may serve on more if so desired. Committees will focus on priority issues determined by the full board and will report in writing on activities, progress and recommendations prior to the monthly meeting. Each committee will select a Chair who will coordinate committee activities. Each committee will be responsible for providing updates of each meeting.
- Committee Recommendations** Recommendations for positions on issues to be taken by the board will be presented in writing by committees for consideration by the full board. Recommendations should be submitted to staff prior to the full board meeting for distribution and review by Board Members prior to the monthly meeting.
- Parliamentary Procedures** The board elects a Parliamentarian each year. The Parliamentarian serves as an advisor to the Chair on parliamentary procedures and ensures that proper parliamentary procedures are adhered to during meetings.
- Public Testimony** Positions will be written and, in addition, may be presented orally by a member selected by the board. The testimony will state whether a position is unanimous or by majority with the actual vote count available on request.

If testimony/opinion needs to be sent prior to the next scheduled meeting, committee members will prepare written testimony/opinion which will be distributed to members.

Reports

Annually, the Board must report to the County Executive and County Council on the following: the board's functions, activities, accomplishments, plans and objectives, including recommendations for changes in board functions.

Staffing

The role of staff is to assist in providing notice of meetings, recording minutes, transmitting meeting materials, and meeting recordkeeping requirements.

M e m b e r s h i p G u i d e l i n e s

Membership

A total of 15 members are appointed by the County Executive and confirmed by the County Council for a term of three years and are considered voting members. Members may serve two consecutive terms. Voting board members are selected to represent a cross section of citizens living or working in the Mid-County Service region. Any member appointed to fill a vacancy occurring prior to the expiration of a term shall be appointed only for the remainder of that term. However, that member would also be eligible to serve two full terms following fulfillment of the vacated term.

Term

Each term is three years in length. Members are eligible to serve two consecutive terms.

Compensation

None. However, members may request reimbursement for mileage and dependent care at rates established by the County for each monthly Board meeting as well as committee meetings. Current reimbursement rates are \$10.00 per meeting for mileage and \$30.00 per meeting for child care costs and are subject to change. Reimbursement forms are included in the orientation book and are also available from staff at any time. Members may submit the form on a quarterly basis and receive a check via mail when the request has been processed.

Financial Disclosure Not required.

Membership Guidelines (con't.)

Duties

Act as **advisors** to the County Executive, the County Council and the Director of the Mid-County Regional Center in identifying demographic, economic, social, educational, and infrastructure issues in the Mid-County service area. Identify area priorities and ways to tailor services to residents of the Mid-County service area. Make recommendations on issues and/or policies established by County agencies. Participate in committees of the board with regard to issues affecting budgets and capital projects, land use and zoning, community awareness and education, legislation, transportation and public safety and other topics which relate to the Mid-County region.

Attendance Policy

Active involvement of all members is required for the board to be effective. If a member must miss a board meeting he or she should notify the board Chair or staff. A member who is absent from 25 percent or more of the scheduled meetings during any six-month period is considered to have resigned from the board. When a member resigns through absence, the Director of the Mid-County Regional Center notifies the County Executive and all members of the board. The County Executive may waive the resignation for illness, emergency, or other good cause.

Liability

Board members have liability protection under the Local Government Tort Claims Act for actions arising out of their scope of employ, i.e. their Board responsibilities. Board members will also receive certain medical benefits; this coverage is limited, however, benefits for reasonable medical treatment comparable to medical benefits payable under the Maryland Workers' Compensation Act. Members must be registered with the County's Risk Management System. Board members should ask staff for the appropriate form.

(con't. on next page)

Membership Guidelines (con't.)

Ethics

The Montgomery County Public Ethics Law prohibits board members from participating in matters involving an economic or fiduciary interest of the member. Board members are also prohibited from participating in a matter that involves an economic interest of a relative. Relatives include siblings, parents, grandparents, children, grandchildren, a spouse, a spouse's relatives and the spouses of these relatives.

The ethics law prohibits Board members from accepting or soliciting gifts from lobbyists and persons doing business with or regulated by the agency with which the committee is affiliated. A Board member must not solicit a gift while identifiable as a member of the Board unless expressly authorized to do so for the benefit of the County by the appropriate authority.

A Board member must comply with the employment provisions of the ethics law. A Board member is not required to obtain approval for employment with respect to employment held when the member was appointed if the Board member publicly disclosed the employment relationship to the appointing authorities before appointment. A Board member must not seek a contract with the County or take as a client an entity that contracts with or is regulated by the agency with which the Board member is affiliated without first referring the matter to the Ethics Commission. A Board member should not represent a person if the person's interest is adverse to that of the County without first referring the matter to the Ethics Commission.

A Board member must not disclose confidential information or attempt to use the prestige of the member's office for private gain or the gain of another. A Board member must not use an official County agency title or insignia in connection with any private enterprise or use a County facility or property for personal use or the use of another unless the use is generally available to the public.

The description of the public ethics law is intended to provide a general overview only. In specific cases, the ethics law itself should be consulted and, where appropriate, a request for an advisory opinion or waiver made to the Ethics Commission.

The Board is responsible for reviewing County Ethics Law periodically with Board membership. Each Board member has a responsibility to adhere to the County's sexual harassment and non-discrimination policies.

Formal ethics training is available to all Board Members on a semi-annual basis. Members will be notified as training opportunities are scheduled.



MID-COUNTY CITIZENS ADVISORY BOARD

Marc Elrich
County Executive

Luisa F. Cardona
Regional Director

Mid-County Citizens Advisory Board Standing Committees

The general area of responsibility of the standing committee is:

The Quality of Life & Budget Subcommittee deals with issues brought to the Board by community members as well as “quality of life” matters pertaining to the Mid-County region.

“Quality of life” matters can include: housing, public safety, education, etc. It also addresses issues involving the County Capital Improvements Program (CIP) and the Public Services Program (PSP), which encompasses the County’s operating budget. The committee helps evaluate CIP issues including improvements for highways, transit, water and sewer, lighting, other utilities, parks and other County property, and other capital expenditures supporting commercial or neighborhood revitalization. It helps evaluate multi-year and annual budget plans supporting County operations and services, including the overall framework of revenues and expenditures as well as any legislative issues under its purview.

AD HOC Committees

The Chair at his or her discretion, may at any time establish any number of ad hoc committees to assist in the performance of any activity in keeping with the purpose of the Board.

Montgomery County, Maryland

GENERAL VOLUNTEER REGISTRATION FORM

Completion of this form is required by all volunteers. The Montgomery County Self-Insurance Program provides medical benefits for volunteers injured while performing duties on behalf of the County as directed by the supervisor, comparable to medical benefits as required to be provided under the Workers' Compensation Law of the State of Maryland. The Montgomery County Self-Insurance Program also provides General Liability Coverage to volunteers consistent with Article 20-37 of the Montgomery County Code and with The Maryland Local Government Tort Claims Act. Details of coverage may be discussed with the Division of Risk Management. Please complete this form as accurately as possible.

Be assured that this information is confidential and for use only by the Division of Risk Management.

Please Type or Print Clearly

Name: _____ *Date of Birth _____

Street Address: _____ Apt. #: _____

City: _____ State: _____ Zip Code: _____

Email address _____ Primary Phone: _____

Volunteer's Area of Specialty: _____

I hereby state that the above information is correct as of this date.

Volunteer's Signature: _____ Date: _____

*VOLUNTEERS UNDER AGE 18 MUST HAVE THE FOLLOWING SECTION COMPLETED BY A PARENT &/OR LEGAL GUARDIAN.

I am the parent and/or legal guardian for _____, a minor. I hereby give my permission for him/her to perform volunteer services for Montgomery County Department of _____

Parent/Legal Guardian Signature: _____ Date: _____

This part to be completed by the Volunteer's County Govt. Supervisor

County Supervisor's Signature: _____ Date: _____

Print Last Name of County Supervisor: _____ Supv. Phone No.: _____

County Department: _____ and Division: _____ (where Volunteer will work)

Please note, the supervisor information must be completed BEFORE the volunteer information is entered in the Risk Management Volunteer Registration System (RMVRS)

Keep completed form with ORIGINAL SIGNATURES in accordance with Departmental Records requirements

Direct any questions to:
Division of Risk Management/Insurance Section
101 Monroe Street, 15th Floor
Rockville, Maryland 20850
240-777-8920

****If you will be driving on behalf of Montgomery County, you must also complete a Driver Volunteer Registration form.

REIMBURSEMENT FORM FOR MEMBERS* OF BOARDS, COMMITTEES, AND COMMISSIONS

This form is to be used to request reimbursement for transportation or dependent care expenses relating to membership on a County Board, Committee, or Commission (BCC). Members should submit this form on a quarterly basis to their BCC staff liaison in the same fiscal year as expenses are incurred. The County's fiscal year is from July 1 – June 30.

BCC Name: _____

Member Name: _____

Address: _____
Street Address

City, State, Zip Code

Phone: (____) _____ (____) _____
Office Home

Dates of Meetings: _____
(month/day/year) (month/day/year) (month/day/year)

Travel Reimbursement: Yes ___ No ___ # of Mtgs. _____ x \$ _____ = _____
(\$10.00 per regularly scheduled meeting or subcommittee meeting)

Dependent Care Expenses: Yes ___ No ___ # of Mtgs. _____ x \$ _____ = _____
(\$30.00 per regularly scheduled meeting or subcommittee meeting)

Total Reimbursement Request: \$ _____

I verify that the above information is correct and request reimbursement for the above expenses.

BCC Member Signature Date BCC Staff Signature Date

BCC Staff Signature also verifies that BCC staff has reviewed the BCC member's attendance record and that the BCC member attended the meetings listed above.

This form should be processed by the accounting staff of the department with which the BCC is affiliated. The codes established in Oracle for these expenses are:

Cost Center Code 99270
Account Code 64504
General Fund – Non Departmental Account - 001

For additional information, please call 240-777-2528 or contact the Department of Finance.

*Does not include "ex officio" members mandated in a BCCs enabling law.

REIMBURSEMENT INSTRUCTIONS FOR STAFF

Reimbursement is for “public” BCC members. Ex Officio members mandated in a BCCs enabling legislation should be reimbursed for travel expenses by the organization with which they are affiliated.

The rate of reimbursement is \$10.00 for transportation and \$30.00 for dependent care for each regularly scheduled BCC meeting or subcommittee meeting attended by a member. No receipts are required for either type of reimbursement.

Reimbursement for virtual meetings is for dependent care only, not transportation.

Reimbursement Forms should be distributed to all new members upon receiving their BCC orientation. Forms should also be available at every meeting. Staff should check completed forms for accuracy, especially in regard to dates of meetings attended.

Reimbursement requests should be processed QUARTERLY in the same fiscal year as expenses are incurred, but may be processed monthly upon request of a member. The County’s fiscal year is from July 1 – June 30.

Steps for processing reimbursement requests:

- 1) BCC member completes Reimbursement Form and submits to BCC staff liaison.
- 2) Staff liaison reviews Reimbursement Form for accuracy and approves.
- 3) Staff liaison submits Reimbursement Form to his/her departmental accounting staff authorized to access the Oracle accounting system.

Cost Center Code 99270
Account Code 64504
General Fund – Non Departmental Account – 001

- 4) Reimbursement check is sent to BCC member.

Note: Social Security numbers are not required for BCC members to receive reimbursements.

Section 4:
Maps & Demographics

Montgomery County Regional Services Centers

The County has five regional services centers: Upcounty, Mid-County, Silver Spring, Bethesda/Chevy Chase, and East County, and five satellite offices

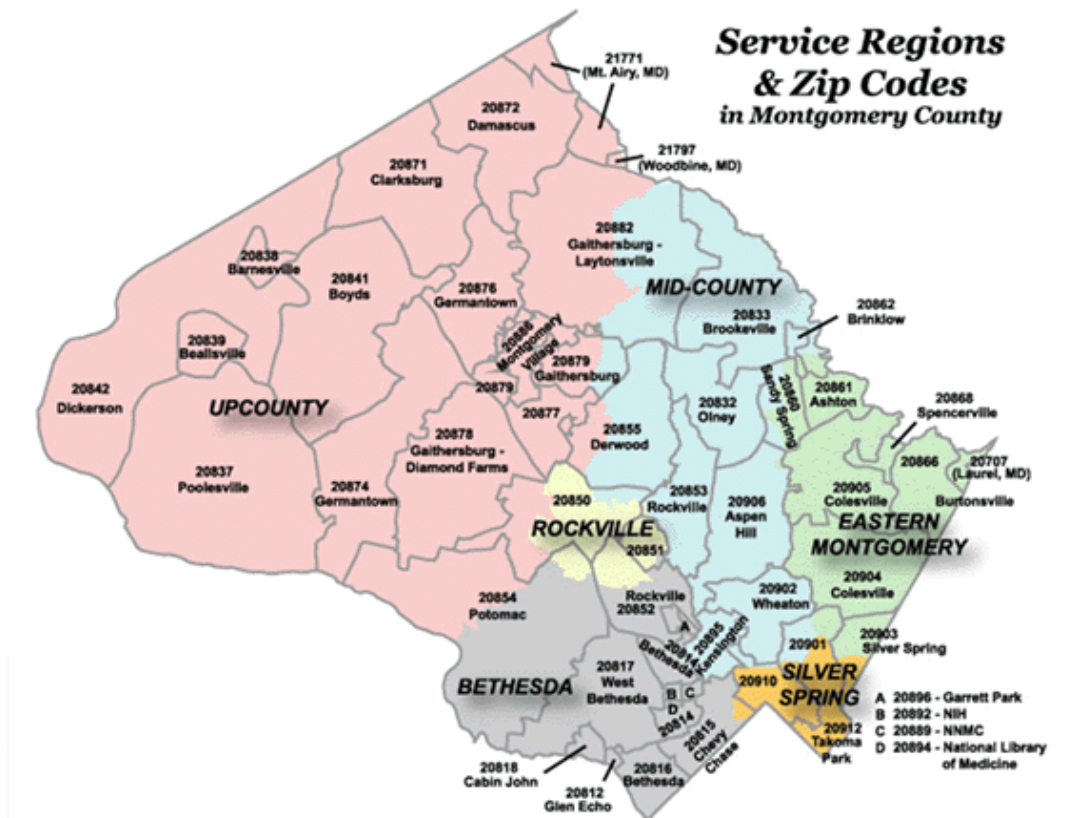

Mission Statement

The mission of the Regional Services Centers is to represent the County in their respective regions by providing effective, timely liaison between Montgomery County and its residents and businesses and by working with individuals, community groups, regional Citizens' Advisory Boards, and other public agencies to provide information, identify and assess regional problems and issues, and recommend and/or implement solutions.

Mid-County Regional Services Area

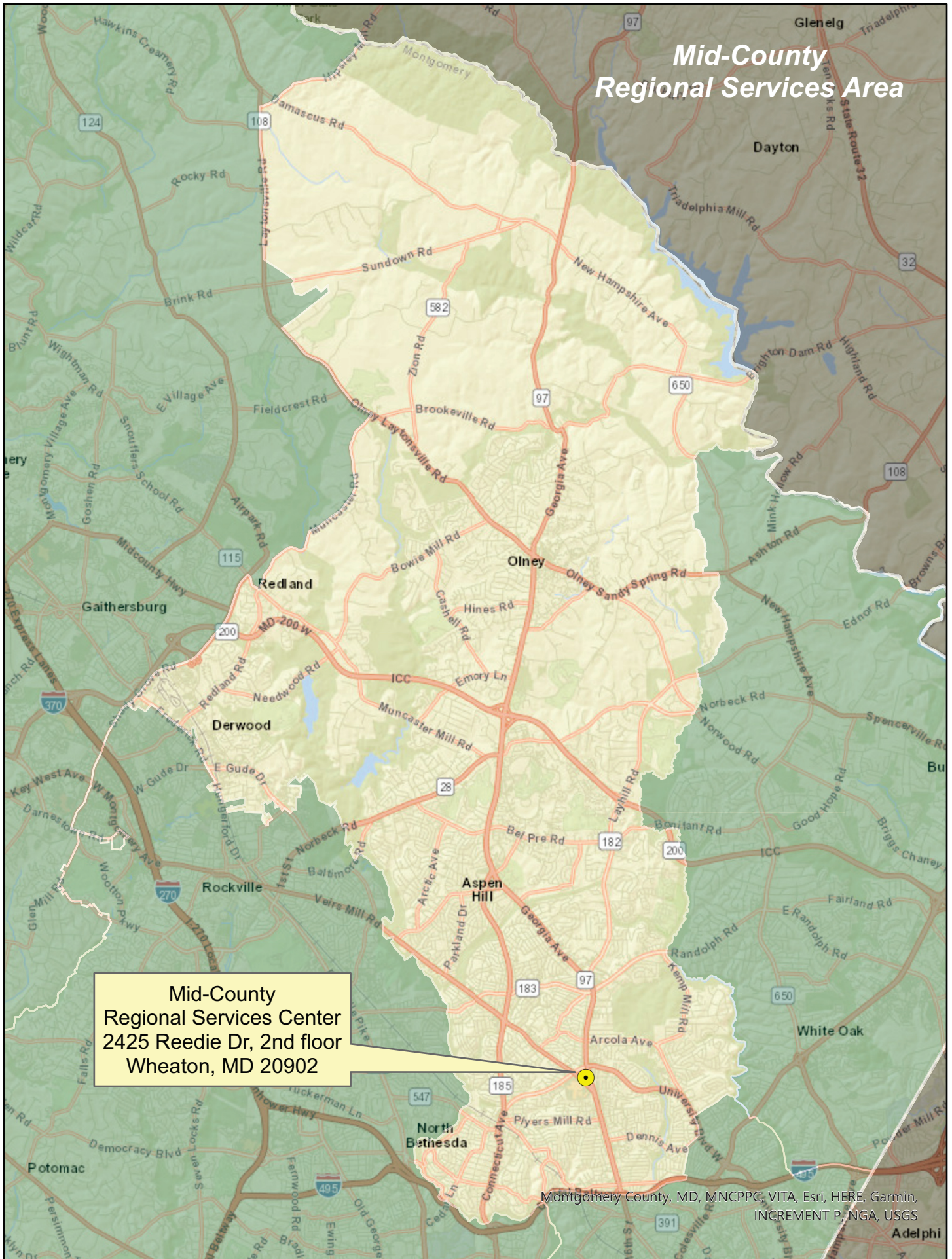

Mid-County
Regional Services Center
2425 Reedie Dr, 2nd floor
Wheaton, MD 20902

Montgomery County, MD, MNCPPC, VITA, Esri, HERE, Garmin,
INCREMENT P, NGA, USGS

Montgomery County Urban Districts





Enhanced services in downtowns:

- Combat urban decay
- Create active urban centers
- Promote businesses
- Maintain clean streets and sidewalks
- Enhance safety

WHEATON



Wheaton

-  Arts & Entertainment District
165.5 acres
-  Central Business District & Transportation Management District (same boundaries)
76.0 acres
-  Enterprise Zone
484.8 acres
-  Parking Lot District
105.4 acres
-  Urban District
201.6 acres

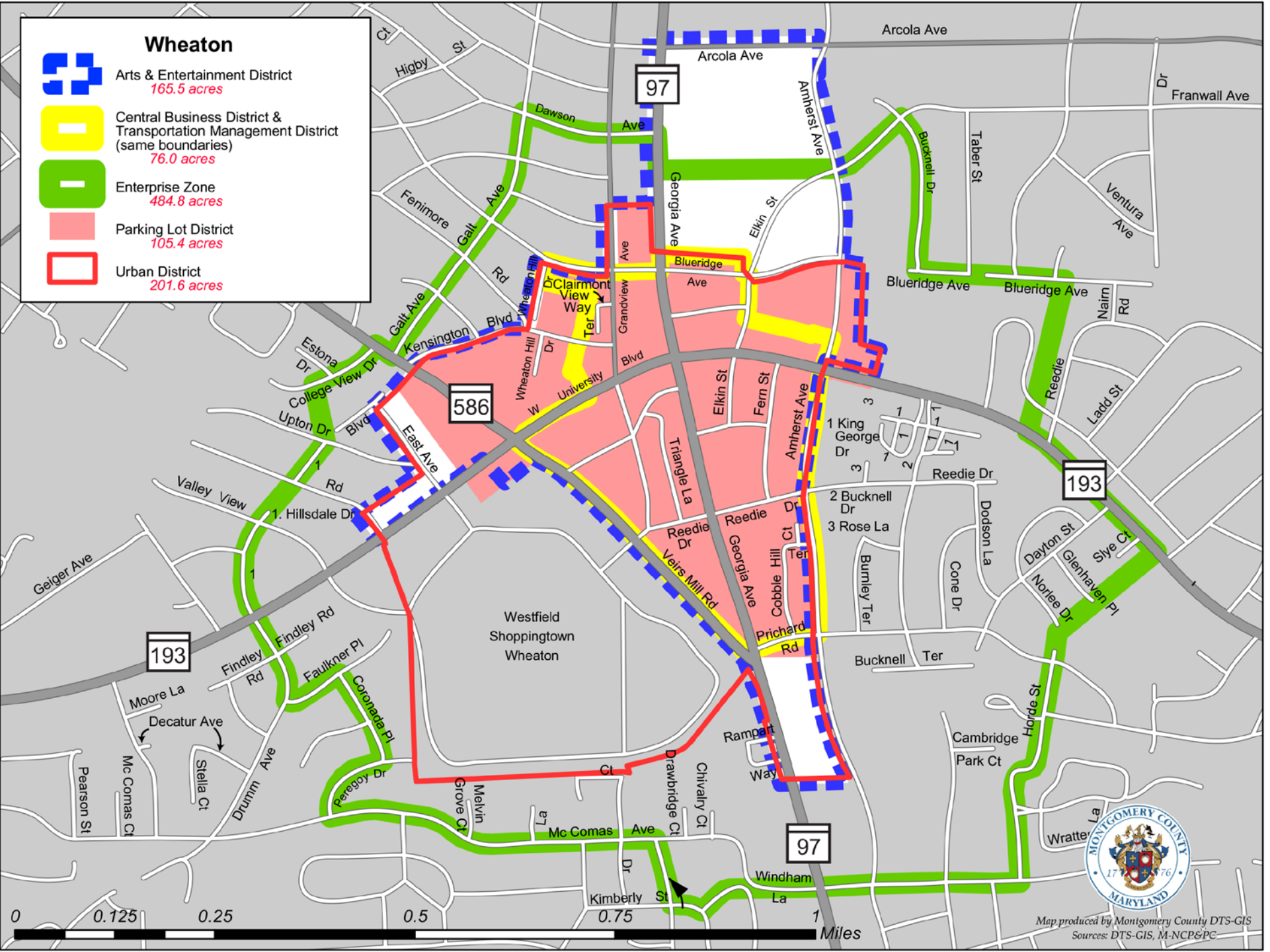

Map produced by Montgomery County DTS-GIS
Sources: DTS-GIS, M-NCP&PC

Mid-County Region Community Data





About Mid-County

The Mid-County Region consists of the communities of **Ashton, Aspen Hill, Brookeville, Capital View, Derwood, Forest Glen, Glenmont, Kemp Mill, Kensington, Layhill, Norbeck, Olney, Sandy Spring, Upper Rock Creek, and Wheaton** communities.

Geography of the Mid-County Region

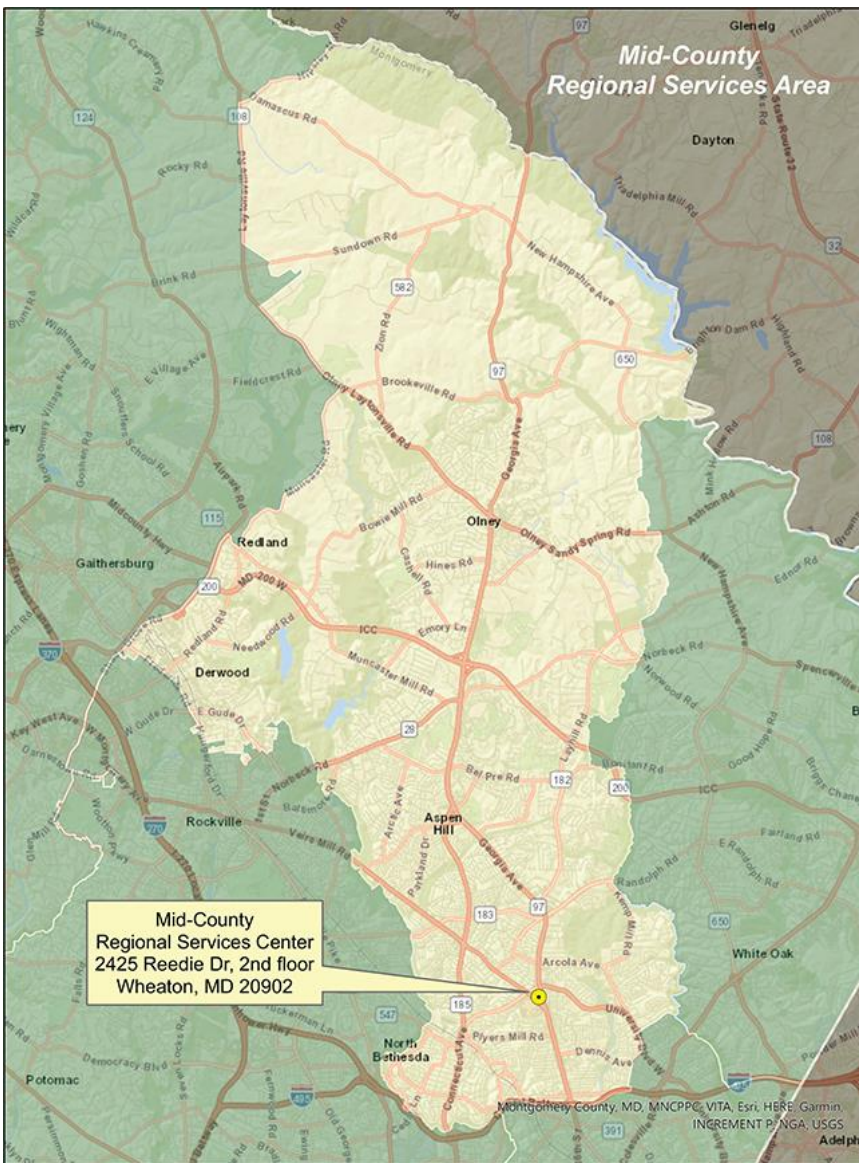

Mid County Population:
189,000
Montgomery County
Population:
1.2 million

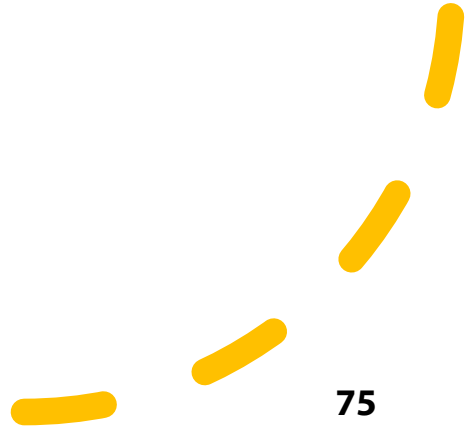



How Our Numbers are Estimated

Our estimates are produced using aggregate data from zip codes and Census Designated Places (CDP's) collected by the 2019 American Community Survey

- Kensington, Layhill, Ashton-Sandy Spring, Forest Glen, Kemp Mill, Glenmont, Olney, Wheaton and Aspen Hill are the CDP's corresponding to the Mid-County Region in the American Community Survey.

Mid-County Population

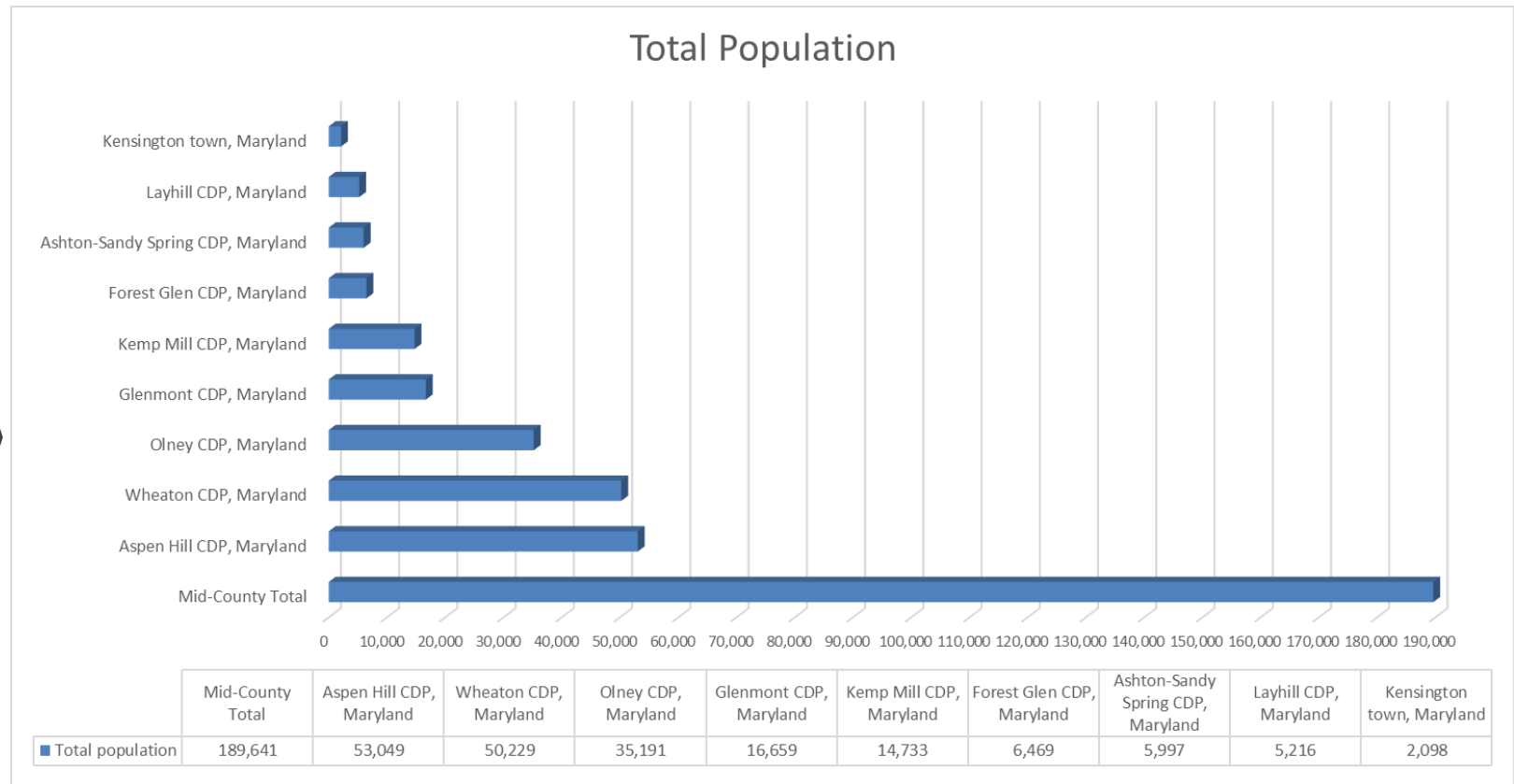

Race in Mid-County

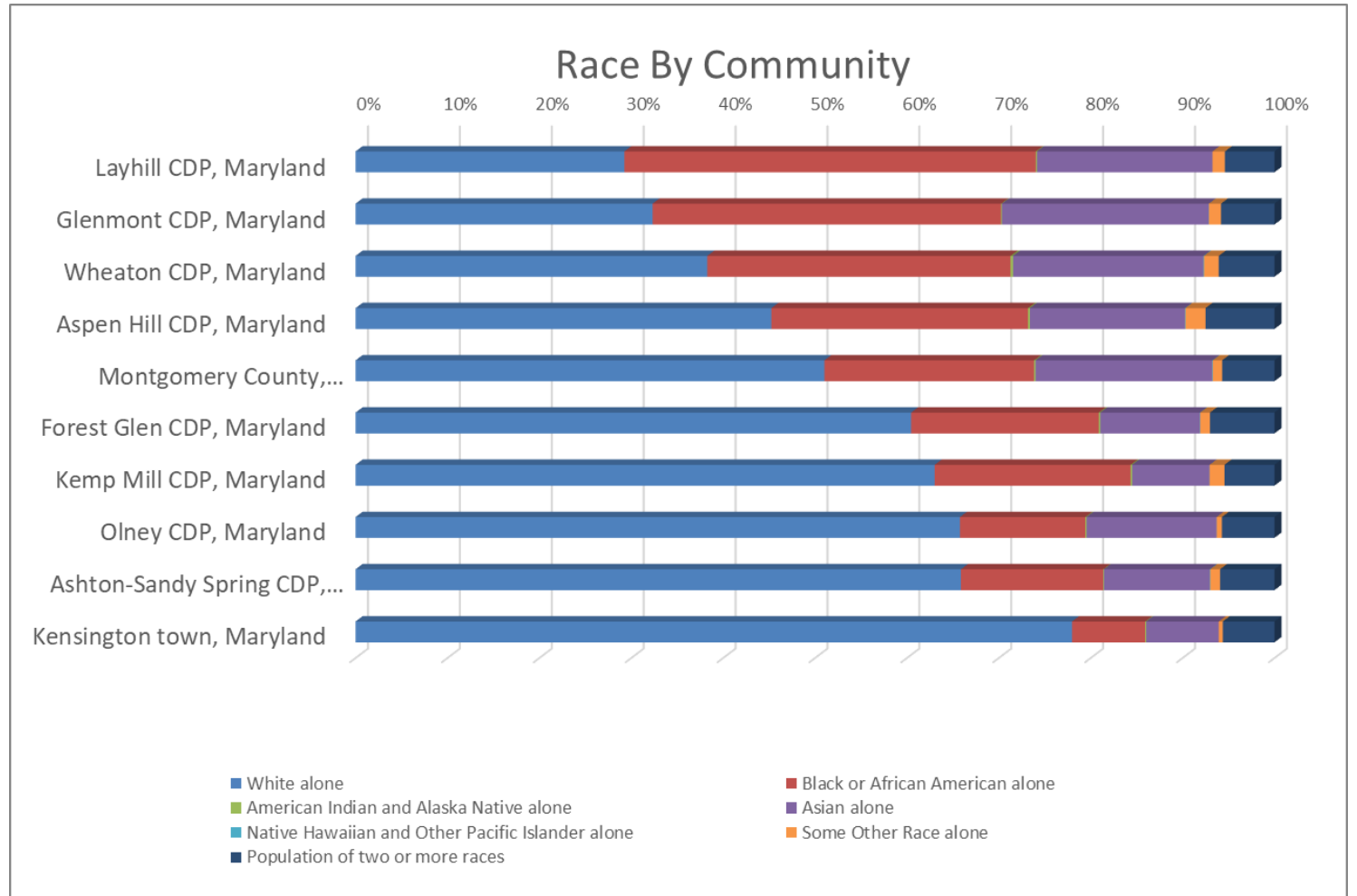

Hispanic Ethnicity in Mid-County

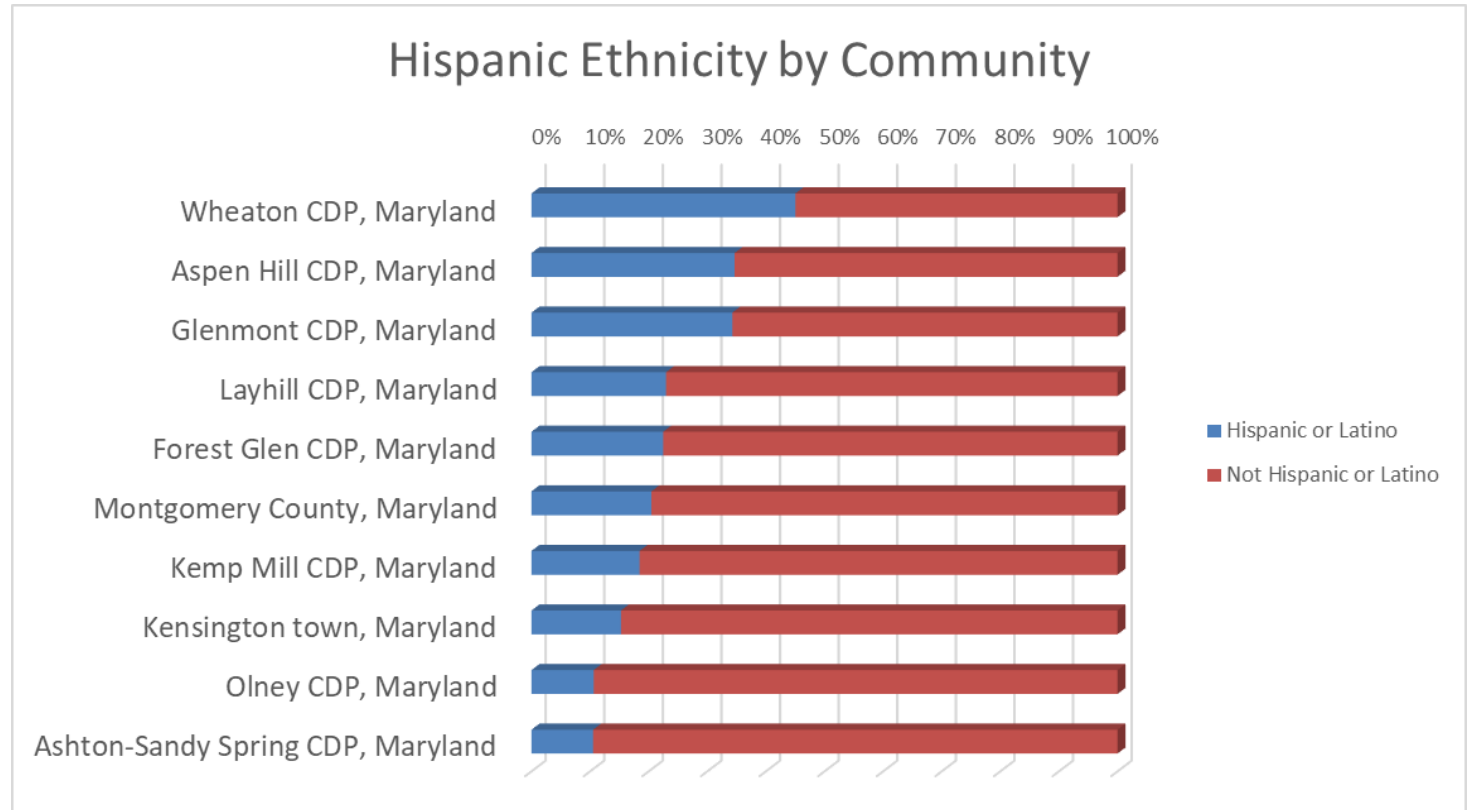

Education in Mid-County

Educational Attainment, Over 25

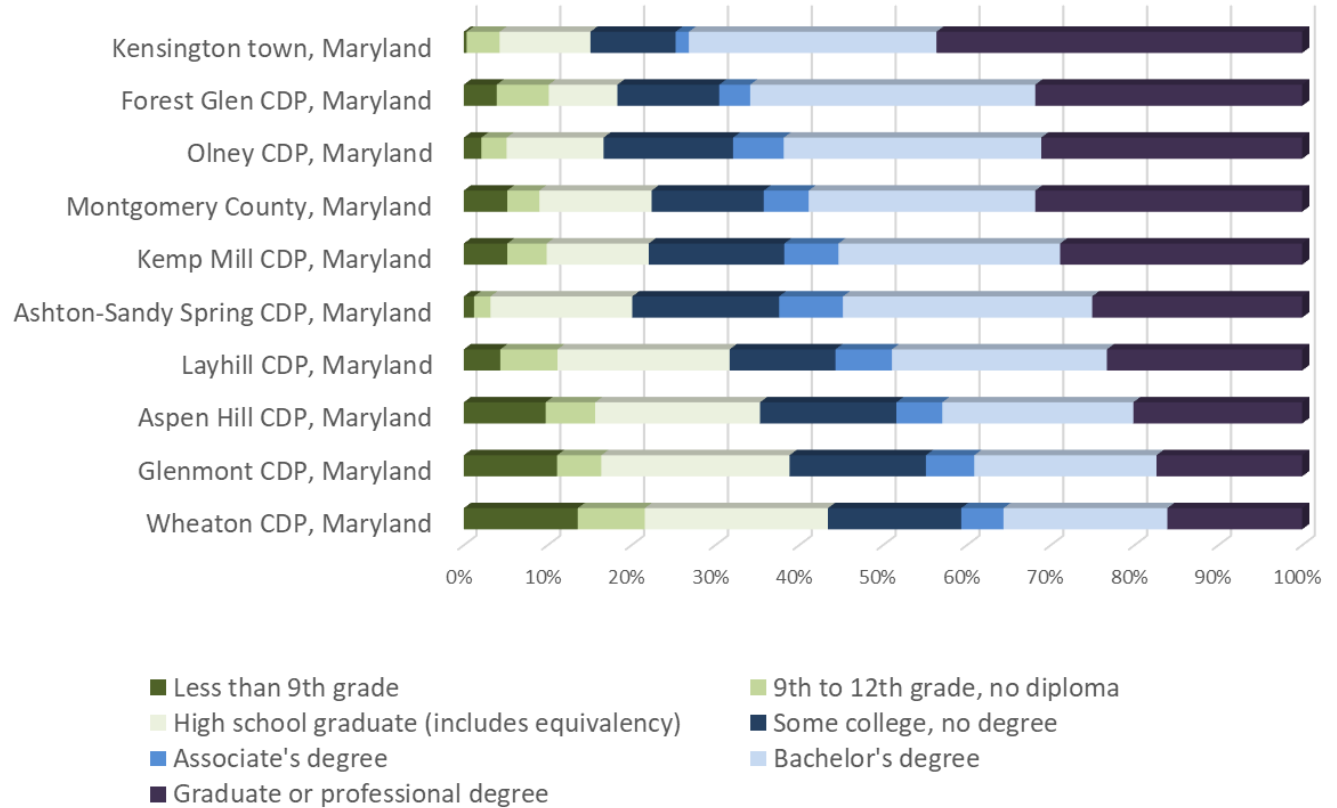

Poverty in Mid-County

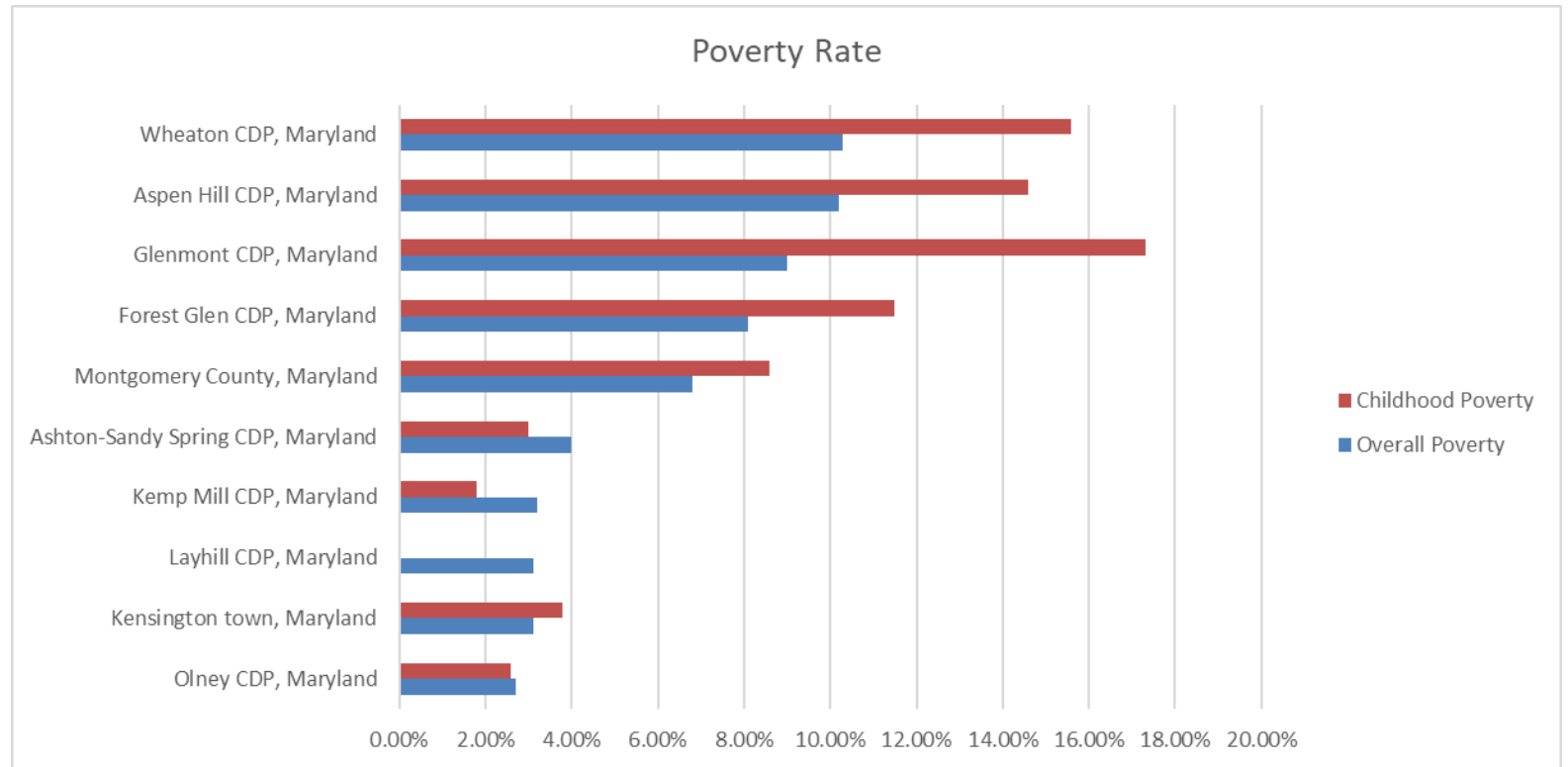

Languages in Mid-County

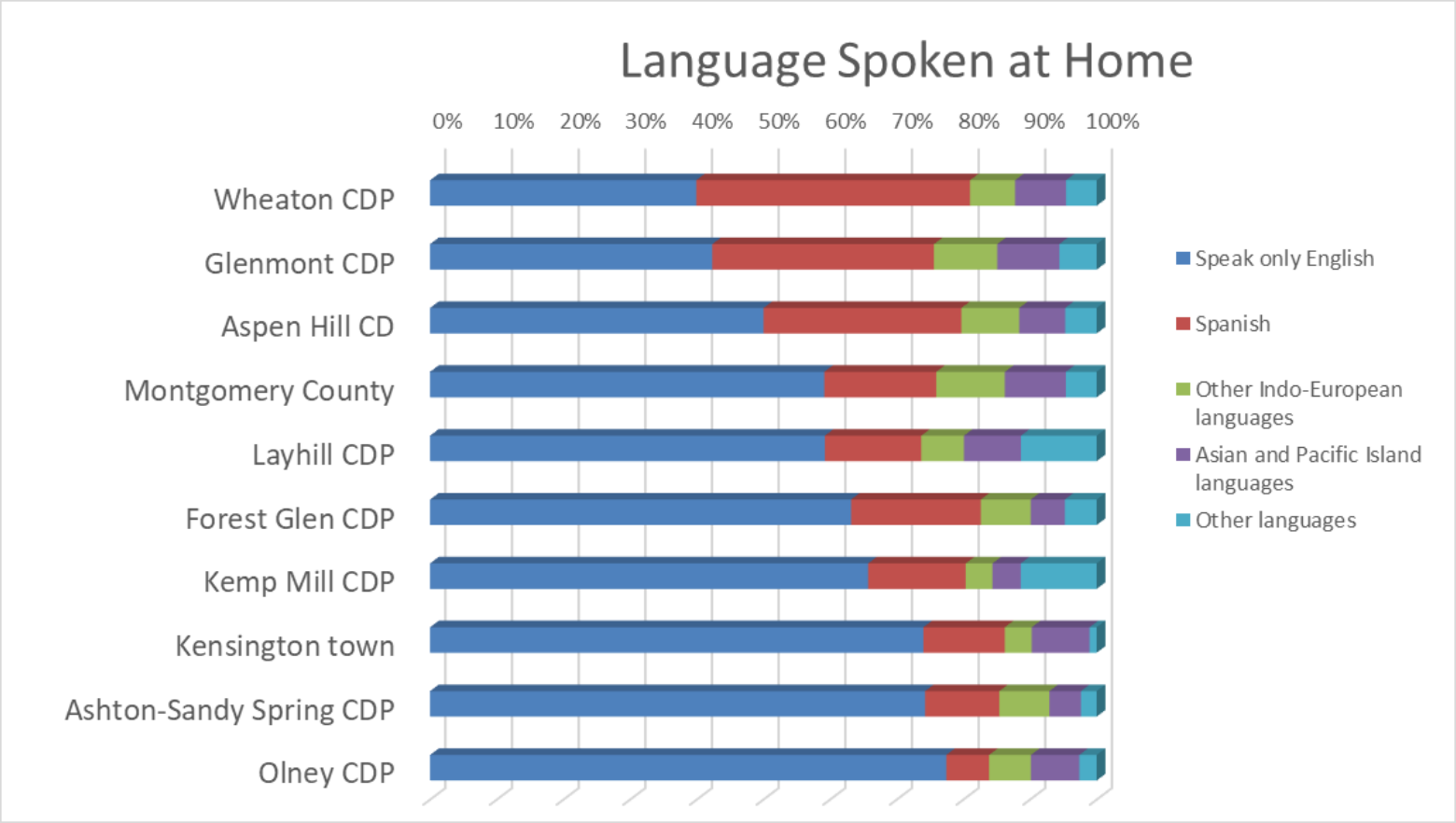

National Origin in Mid-County

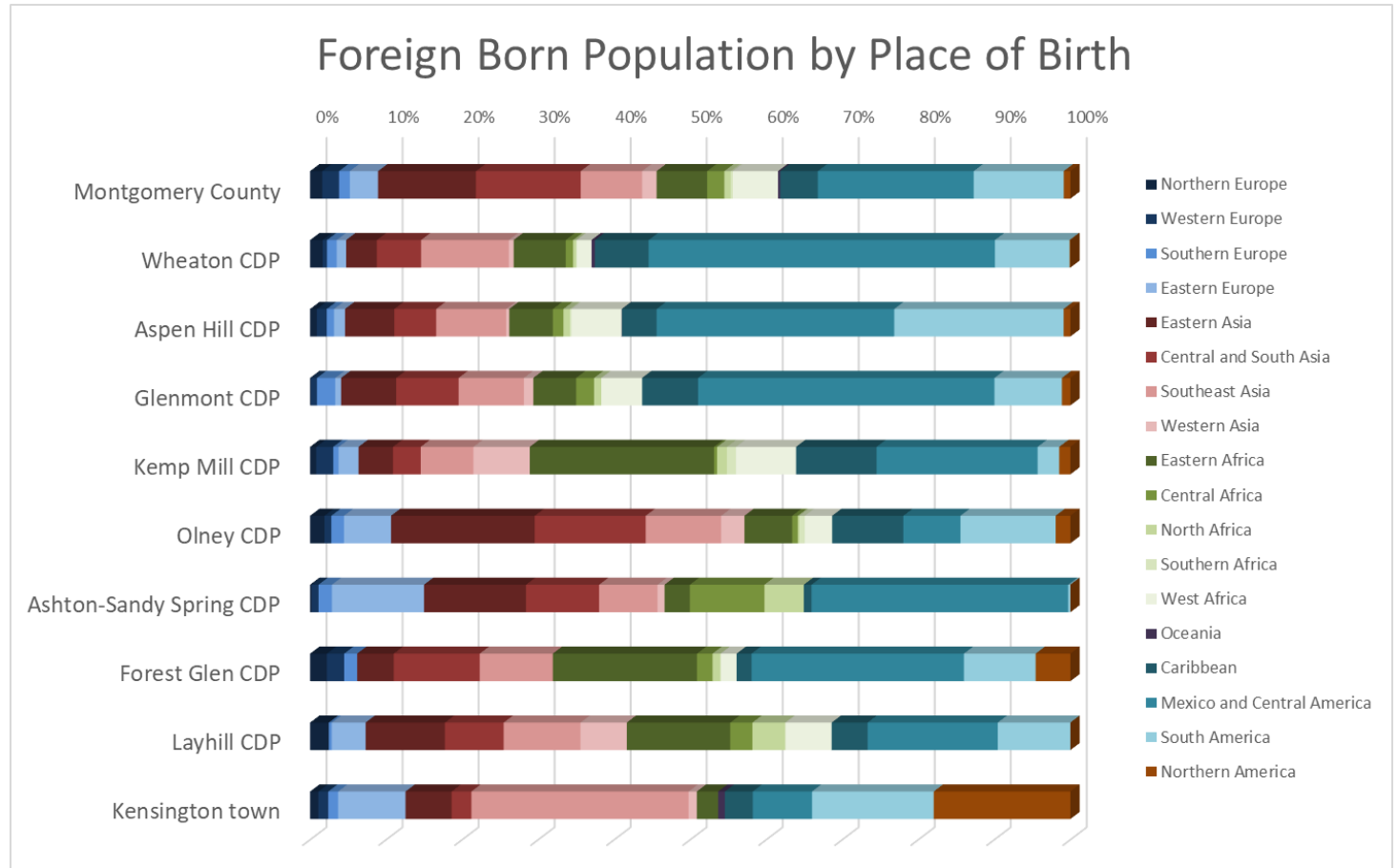

Food Insecurity Heat Map

Source: Capital Area Food Bank 2021-2022

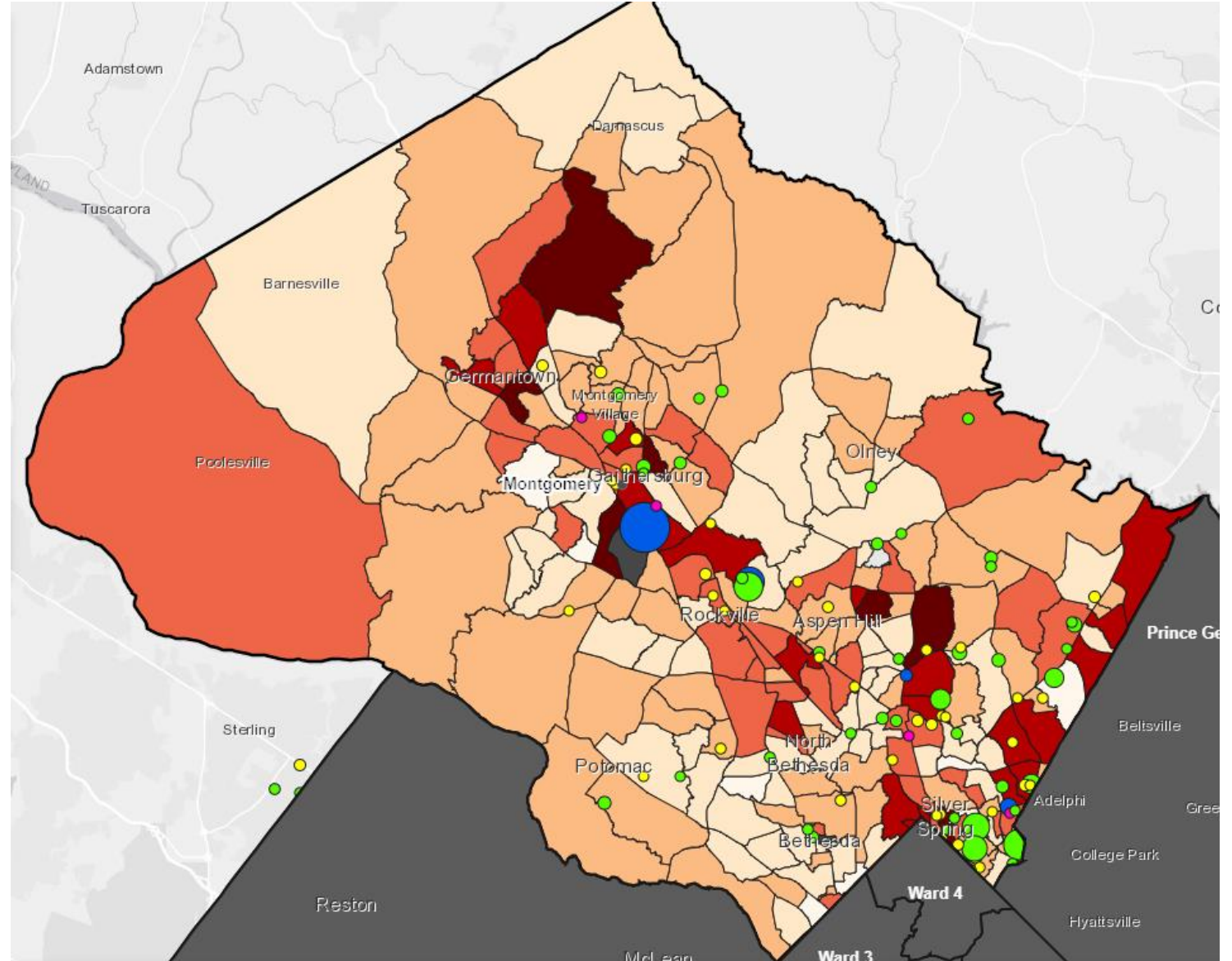
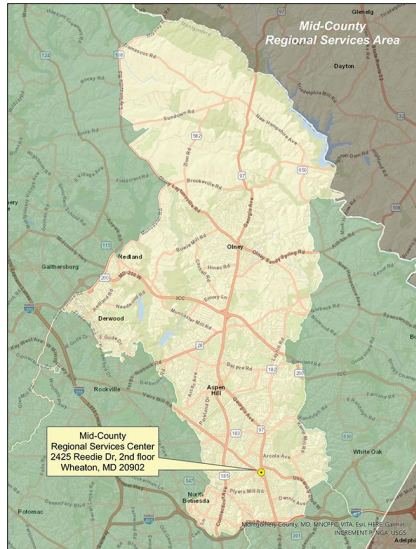

Created By: Gwendolyn Peyton | Montgomery County Council Fellow | Summer 2022
Last Updated 8/8/2022





MID-COUNTY REGIONAL SERVICES

The **Mid-County Regional Services Office** is one of five regional services area offices designed to bring direct services to the public and to enhance communication between residents and County government. The Office's four core functions include 1) coordinating projects among multiple agencies in their respective region; 2) assisting department with outreach to communities (and vice versa); 3) providing additional knowledge to departments about their respective regions (and vice versa) and 4) helping departments be responsive to the community's needs. Over the years, the Mid-County Office has helped to facilitate many public-private partnerships for the benefit of the residents and businesses located throughout the 99 square miles that make up the service area for the Mid-County Regional Office.

Administration

The Office is led by the Mid-County Regional Office Director who offers problem solving, information, and referrals to residents and businesses. Staff work directly with residents, community groups, businesses, the Mid-County Citizens Advisory Board, the Wheaton Urban District Advisory Committee, and numerous public and private agencies to assess regional area problems, to determine solutions that emphasize cooperative efforts, and to foster public-private partnerships.

The Mid-County Office staff provide:

- Information about direct services
- Responses to requests for services
- Problem solving assistance and advice
- Staffing of Mid-County and Wheaton Boards and Committees
- Referrals to other agencies

The Director for the Mid-County Regional Services Office is **Luisa F. Cardona**. She can be reached at 240-777-8101 or luisa.cardona@montgomerycountymd.gov.

Mid-County Citizens Advisory Board

An 15-member Board, appointed by the County Executive and approved by the County Council, to provide advice to County Government on matters affecting the Mid-County region and the 220,000 residents and businesses in the 99 square miles of the service area.

Meets the third Tuesday of each month (except in August) at 7:00 p.m. in the Mid-County Community Recreation Center (2004 Queensguard Road, Silver Spring, MD). Meetings are open to the public.

Wheaton Urban District Advisory Committee

An 11-member Committee, appointed by the County Executive and confirmed by the County Council, to provide advice on all issues affecting the Wheaton Urban District.

Meets the second Tuesday of every month (except in August) at 6:30 p.m in the Wheaton Volunteer Rescue Squad (2004 Arcola Ave, Wheaton, MD). Meetings are open to the public.



MID-COUNTY REGIONAL SERVICES

The Mid-County Regional Services Office includes a population of approximately 220,000 residents and businesses in an area that extends from the Beltway to Howard County.

Serving the communities of:
Aspen Hill, Brookeville, Capital View, Derwood, Forest Glen, Glenmont, Kemp Mill, Kensington, Layhill, Norbeck, Olney, Sandy Spring, Upper Rock Creek, & Wheaton.

Sign-up for Mid-County e-Newsletter: www.goo.gl/3YYMDG

Wheaton Urban District Clean & Safe Team

The **Wheaton Urban District** provides special services to the Central Business District to ensure that downtown Wheaton is maintained in a clean, safe, and attractive manner to promote a vibrant social and business environment. For information about businesses, events, and developments in the Wheaton Urban District, go to wheatonmd.org.

The Clean and Safe Teams (recognized by their red shirts) provide landscaping, maintenance, and concierge services to the businesses and patrons in the Urban District. Their goal is to make Wheaton a better place to live, visit, and do business. To contact a Safe Team member, call the hotline at 240-777-8120.

